

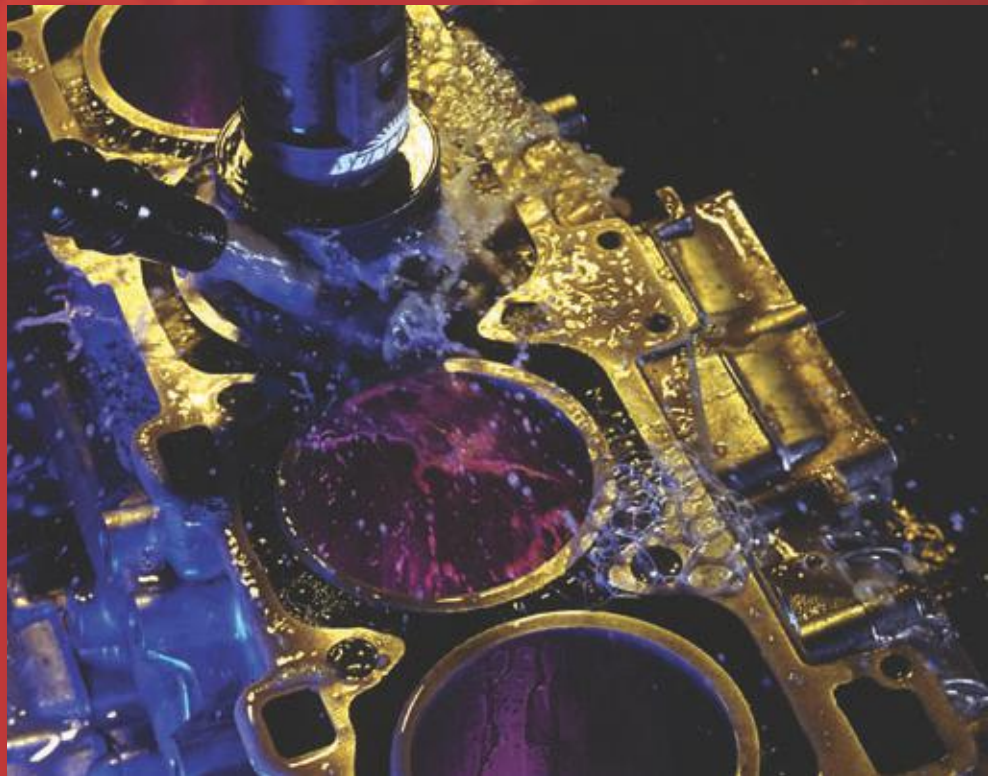

# ENGINE HONING TOOLING AND ACCESSORIES

ABRASIVES | TOOLING | GAGING | FIXTURING | LUBRICANTS | ACCESSORIES



# WE APPRECIATE THE OPPORTUNITY TO SERVE YOU...

## Our Global Commitment

Sunnen began selling machines and accessories internationally shortly after the company was founded in 1924. Headquartered in St. Louis, Missouri, Sunnen's worldwide network includes more than 50 authorized distributors. Sunnen's international facilities extend to Switzerland, Italy, the United Kingdom, Poland, Brazil, Belgium, France, Russia, the Czech Republic and China. We are committed to providing products and services wherever they are needed in the world.

Since its beginning Sunnen has concentrated on the technology of precision honing. Today we are the largest, fully integrated company in this field with more than 500 employees.

In this catalog we have assembled a comprehensive guide on tooling, accessories and supplies available for our extensive line of engine building honing machines. The format makes it easy for you to determine your needs and to order everything required for your operation.

Of course, if you have questions, Sunnen's Customer Service is ready to help. Sunnen takes pride in being an organization of friendly, dedicated people ... committed to serving your needs.

## World Class Sunnen Abrasives

As the world's foremost authority on honing, Sunnen has incorporated almost 90 years of research and development into a complete and top-quality line of honing abrasives.

Sunnen has a facility in St. Louis dedicated solely to the research, development and manufacturing of abrasives, plated diamond tooling and honing lubricants.

With Sunnen abrasives, you get exactly what you need, when you need it. Before any stone is shipped, we grade and qualify it requiring it to endure the most exacting quality-control standards in the industry to assure you of the most precise honing performance available today.



## Technical Expertise – Second to None

Sunnen's Technical Center includes many of the industry's most knowledgeable honing and engine building experts. To ensure superior precision and the highest product quality, no other company in the industry has the extensive complement of high-tech equipment used in the development and testing of machines, tools and abrasives.

## Service in Your Shop

Sunnen's factory-trained sales engineers and service specialists help get your new Sunnen equipment set up and running, and they follow through to help solve technical problems, train new operators and keep you up-to-date on shop operations.

## Built and Backed by Sunnen

The Sunnen brand is your assurance of precision and quality. Sunnen tooling, abrasives, honing fluids, bore gages and accessories are designed to fit the specific requirements of our equipment ... and to meet the high standards that have made Sunnen Products Company the world leader in honing technology since 1924.

**If You Have Questions or Need  
Technical Assistance...  
Just Call Toll Free (in the USA):**

**1-800-325-3670**

Customers Outside the U.S.A.,  
please Contact Your Local  
Authorized Sunnen Distributor.

**[sunnen.com](http://sunnen.com)**

*Sunnen equipment, accessories and supplies are manufactured in our 45,150 sq. meter (486,000 sq. ft.) plant equipped with the most advanced production and quality control systems.*

# SUNNEN ENGINE REBUILDING EQUIPMENT..

## For Nearly 90 Years Sunnen Has Been the Leader in Honing.

Whether for connecting rods, piston pin bores, cylinder or main bearing bores, we have the right honing system for you.



### Rod Reconditioning

Four systems, the **LBB-1660** manual hone, **ML-2000**, **ML-4000** and the **ML-5000** power stroked honing systems offer versatility and accuracy when honing connecting rods.



### Cylinder Bore Reconditioning

The **SV-10** and **SV-20** are the standards in the industry for cylinder bore honing in all types of engine blocks.



### OEM/Production Cylinder Honing

Sunnen's **SV-2400** Series honing systems are a cost effective solution for production honing applications.



### Line Honing

Sunnen's dependable **CH-100** is the best method for fast precision alignment of main bearing bores.

# PERFECT FOR ALL YOUR ENGINE HONING NEEDS

## Sunnen Leads the Way in Automotive Honing Equipment with:

- A complete line of honing systems for connecting rods, piston pin bores, cylinder or main bearing bores
- Tooling and fixturing, including custom fixturing, for all your engine honing needs
- Abrasives and diamond tooling
- Honing oils and water based coolants
- Electronic and mechanical bore gages
- A nationwide team of factory-trained representatives with solutions to your equipment needs
- Personal customer service for fast, easy ordering
- Technical advice and field service that is second to none

**Check the Table of Contents for Tooling and Accessories to Fit Your Machine and Application.**



## Table of Contents Honing Products

---

<b>Cylinder Heads</b> .....	<b>5-6</b>
External Honers .....	5
Valve Guide (Honall®) .....	6

---

<b>Connecting Rods</b> .....	<b>7-21</b>
Honing Mandrels .....	7-15
Machine Accessories .....	16-17
CRT .....	18
SRT .....	19
Keyway Honers .....	20
Honing Oils & Coolants .....	21

---

<b>Block Reconditioning</b> .....	<b>22-48</b>
DH-Series Diamond Honing System Tooling & Accessories .....	22-23
SV-10/SV-20/SV-400/SV-2400/CV/CK Tooling & Accessories .....	24-36
CH-100 & Supplies .....	37-39
Portable Honers & Accessories .....	40-48

---

<b>Gaging</b> .....	<b>49-62</b>
---------------------	--------------

For our complete line of non-honing accessories and supplies see catalog # A-7650.

[sunnen.com](http://sunnen.com)



# Online Ordering 24/7



Place your orders online @  
**www.sunnen.com**

# External Honers & Accessories

## External Hone Sets



Each set contains hone body, wrench, F-700 dressing stick, and two each of stones and guide shoes needed for stock removal and surface finishing. Ordering in Sets saves you approximately 10%.

External Hone Stone	Diameter Range		Hone Body	Honing Stones				Guide Shoe (2 of each)
	inches	mm		For Stock Removal		For Finishing		
F-1	.125-.4062	3-10	FA-E	FA4-AA73	FA4-AA75	FA4-AA93	FA4-AA95	FA4-B
				FA8-AA73	FA8-AA75	FA8-AA93	FA8-AA95	FA8-B
				FA10-AA73	FA10-AA75	FA10-AA93	FA10-AA95	FA10-B
F-2	.4062-.8125	10-20	FB-E	FB13-AA73	FB13-AA75	FB13-AA93	FB13-AA95	FB13-B
				FB19-AA73	FB19-AA75	FB19-AA93	FB19-AA95	FB19-B
F-3	.4062-1.5	20-38	FC-E	FC26-AA73	FC26-AA75	FC26-AA93	FC26-AA95	FC26-B
				FC36-AA73	FC36-AA75	FC36-AA93	FC36-AA95	FC36-B
F-4	1.5-2.75	38-70	FD-E	FD48-AA73	FD48-AA75	FD48-AA93	FD48-AA95	FD48-B
				FD64-AA73	FD64-AA75	FD64-AA93	FD64-AA95	FD64-B

## Selection of External Hone Tooling

Diameter Range		Hone Body	Guide Shoes		Honing Stone	Length of Stone or Guide Shoe	
inches	mm		For All Metals	For use with Diamond or CBN/Borazon Stones only		inches	mm
.120-.240	3-6	FA-E	FA4-B	FA4-BB*	Select From Chart Below	.5	13
.240-.300	6-8		FFA4-B	FFA4-BB*		1	25
.300-.400	8-10		FA8-B	FA8-BB		.75	19
.400-.580	10-15	FB-E	FA10-B	FA10-BB		1	25
.580-.800	15-20		FB13-B	FA13-BB		1	25
.800-1.100	20-28	FC-E	FB19-B	FA19-BB		1.5	38
1.100-1.500	28-38		FC26-B	FC26-BB		2	51
1.500-2.000	38-51		FFC26-B	FFC26-BB		4	102
2.000-2.750	51-70	FD-E	FC36-B	FC36-BB		2.5	64
2.750-4.500	70-115		FD48-B	FD48-BB		3	76
		FD-E N88X	FD64-B	FD64-BB	4	102	

## External Hone Adapter Chucks



Fit Sunnen Honing Machine spindles. Hold work being rotated for external honing operations.

Part No.	Diameter Range	
	inches	mm
MB-748	0"-.375"	0-10
MB-750	.1875"-.75"	5-19
MB-770	.125"-5"	3-127

## 3 Stone for External Honers

Diameter Range		Hone Body with Multiple Holder	Hone Body (one stone reqd.)	For Stock Removal (Numbers listed with materials indicate approximate finish in microinches)			For Fine Finishing on previously honed parts				For Polishing on previously finished honed parts
				Hard Steel*, 10 Soft Brass, 25 Cast Aluminum, 25	Soft Steel, 15 Wrought Aluminum, 25 Bronze, 25	Diamond Stones Carbide, 20 Ceramic, 40 Glass, 70	Hard Steel, 3 Soft Brass, 12 Cast Aluminum, 12	Soft Steel, 4 Wrought Aluminum, 12 Bronze, 12	Diamond Stones 400 Grit 7 3 20 15 30 15		
inches	mm										
.120-.240	3-6	FB-E With FB-FA	FA-E	FA4-AA73	FA4-AA75	FA4-DV57	FA4-AA93	FA4-AA95	FA4-DV87	FA4-DV07	FA4-CC05
				FFA4-AA73	FFA4-AA75	FFA4-DV57	FFA4-AA93	FFA4-AA95	FFA4-DV87	FFA4-DV07	FFA4-CC05
				FA8-AA73	FA8-AA75	FA8-DV57	FA8-AA93	FA8-AA95	FA8-DV87	FA8-DV07	FA8-CC05
.240-.300	6-8	FC-E With FC-FB	FB-E	FA10-AA73	FA10-AA75	FA10-DV57	FA10-AA93	FA10-AA95	FA10-DV87	FA10-DV07	FA10-CC05
.300-.400	8-10			FB13-AA73	FB13-AA75	FB13-DV57	FB13-AA93	FB13-AA95	FB13-DV87	FB13-DV07	FB13-CC05
.400-.580	10-15			FB19-AA73	FB19-AA75	FB19-DV57	FB19-AA93	FB19-AA95	FB19-DV87	FB19-DV07	FB19-CC05
.580-.800	15-20	FD-E With FD-FC	FC-E	FC26-AA73	FC26-AA75	FC26-DV57	FC26-AA93	FC26-AA95	FC26-DV87	FC26-DV07	FC26-CC05
.800-1.100	20-28			FFC26-AA73	FFC26-AA75	FFC26-DV57	FFC26-AA93	FFC26-AA95	FFC26-DV87	FFC26-DV07	FFC26-CC05
1.100-1.500	28-38			FC36-AA73	FC36-AA75	FC36-DV57	FC36-AA93	FC36-AA95	FC36-DV87	FC36-DV07	FC36-CC05
1.500-2.000	38-51	None available	FD-E	FD48-AA73	FD48-AA75	FD48-DV57	FD48-AA93	FD48-AA95	FD48-DV87	FD48-DV07	FD48-CC05
2.000-2.750	51-70			FD64-AA73	FD64-AA75	FD64-DV57	FD64-AA93	FD64-AA95	FD64-DV87	FD64-DV07	FD64-CC05
2.750-4.500	70-115	None available	FD-E-N88X	FD64-AA73	FD64-AA75	FD64-DV57	FD64-AA93	FD64-AA95	FD64-DV87	FD64-DV07	FD64-CC05

NOTE: If double length stone is used (FFA4- or FFC26-), you must use guide shoes with identical prefix. Example: Use FFA4-AA73 stone with FFA4-B shoe.  
\*CBN/Borazon® Stones are available for honing very hard materials such as High Speed Steels, 400C Stainless, Inconel 718, Nitralloy, 52100 Steel, etc.

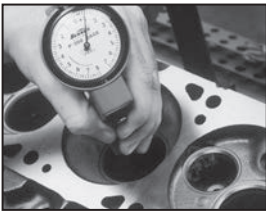

# Valve Guide Sizing

Sunnen HONALL®

- Produces straight, round holes
- Fast setup
- Easy-to-use

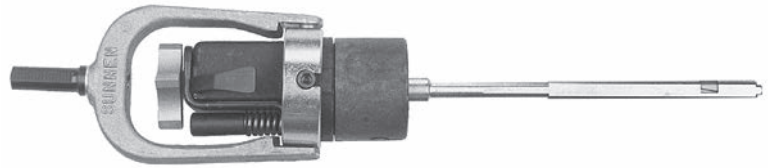

## P-190 Valve Guide Hone Set

Available to cover most popular sizes. A .375" drill (200 rpm) is recommended for driving power.

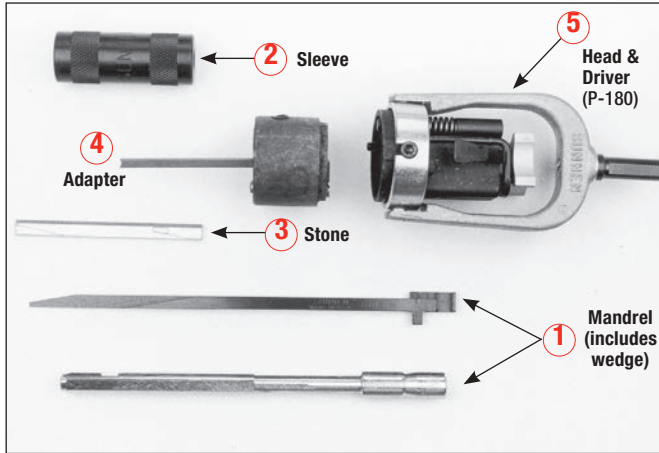

## Ordering Information

The head and driver are interchangeable with the adapters. Only one head and driver is required. Mandrels are available to cover all popular sizes. Please select the parts desired from photograph and order from the chart for the range desired. We recommend that an adapter be purchased for each mandrel. This saves change-over time going from one mandrel to another.

Additional Mandrel Sizes Available - Call Sunnen Customer Service Department.

## AN-1075 Speed Control Unit



Furnished with on/off switch, fuse, AC cord and grounded AC outlet plug. Reduces rpm when used with AC/DC drill motors and motors (brush-type only) where ampere rating is 15 amps or less.

Nominal Fractional Size (inches)	Range inches	Range mm	1 Mandrel	2 Sleeve	3 Stone		4 Adapter	5 Head & Driver
					Old	New		
.1875	.185-.190	4,7 - 4,8	BL6-185CS	S-185	—	L6-J67	Order both:	P-180 200 rpm max
-	.195-.200	4,9 - 5,1	BL6-195CS	S-195	—	L6-J67	PSK6-A	
.2187	.215-.220	5,5 - 5,6	BL6-215CS	S-215	—	L6-J67	LN-3087C	
.2343	.235-.240	6,0 - 6,1	BL6-235CS	S-235	—	L6-J67	†	
-	.255-.260	6,5 - 6,6	BL8-255AS	S-255	—	L8-J67	PK8-A	
.2656	.270-.275	6,8 - 7,0	BL8-270AS	S-270	—	L8-J67	PK8-A	
-	.275-.280	6,9 - 7,1	BL8-275AS	S-275	—	L8-J67	PK8-A	
.3125*	.308-.316	7,8 - 8,0	BL10-308AS	S-308	LG-13	L10-J69	PK10-A	
.3437*	.339-.347	8,6 - 8,8	BL10-339AS	S-339	LG-13	L10-J69	PK10-A	
.3593	.354-.362	9,0 - 9,2	BL10-354AS	S-354	LG-13	L10-J69	PK10-A	
.375*	.370-.385	9,4 - 9,8	BL12-370AS	S-370	LH-13	L12-J67	PK12-A	
.4062	.400-.416	10,2 -10,6	BL12-400AS	S-400	LH-13	L12-J67	PK12-A	
.4375*	.432-.447	11,0 -11,4	BL12-432AS	S-432	LH-13	L12-J67	PK12-A	
.4687	.463-.479	11,8 -12,2	BL12-463AS	S-463	LH-13	L12-J67	PK12-A	
.5	.495-.526	12,6 -13,4	BL16-495AS	S-495	LJ-13	L16-J67	PK16-A	
.5468	.526-.557	13,4 -14,1	BL16-526AS	S-526	LJ-13	L16-J67	PK16-A	
.5625	.557-.588	14,1 -14,9	BL16-557AS	S-557	LJ-13	L16-J67	PK16-A	
.625	.619-.650	15,7 -16,5	BL20-619AS	S-619	LJ-13	L20-J67	PAK16-A	
.6562	.650-.681	16,5 -17,3	BL20-650AS	S-650	LJ-13	L20-J67	PAK16-A	
.6875	.681-.713	17,3 -18,1	BL20-681AS	S-681	LJ-13	L20-J67	PAK16-A	
.75	.744-.775	18,9 -19,7	BAL20-744LA**	S-744	LM-13	L20-J67	PAK20-A	

\*P-190 Valve Guide Honing Set consists of 1 each mandrel and sleeve for the popular .275", .3125", .3437", and .375" sizes; also includes PK8-A, PK12-A, P-180, AN-1105A Storage Box, and 6 each L8 — J67 Stones.

\*\* Replaceable shoe type mandrel. Replacement shoe Part No. LA-C (2 required).

† Remove the LN-3087A stone retainer (standard part supplied with the PSK6-A adapter) and replace with the LN-3087C. The LN-3087C must be ordered separately. AN-1105A Storage Box available for convenient storage of tooling.



# Lifetime Honing Units

## For King Pin Fitting

**Range: .744"-2.625"**  
**(18,9-66,7 mm)**

Replaceable shoe type honing units. Multiple stone length hones both bushings at once—ensures perfect bushing alignment.

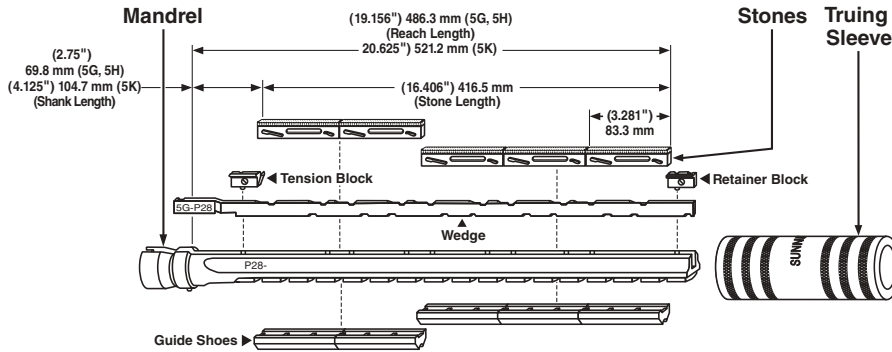

Note: Catalog part numbers referencing old and new are for inventory purposes only. Part is unchanged. Mandrel can be used with fewer than 5 stones for shorter parts which require long reach.

### Honing Units

For Complete Honing Unit Order		Mandrel (Includes Wedge and Shoes)		Truing Sleeve	Stones										Replacement Parts (Included with Mandrel)		Length of Honing Stone Surface	
1 2 3		1	2	3	P20-Type (12 per Pkg.) P28-Type (12 per Pkg.)										Shoe (2 per Pkg.)	Shim Sets	inches	mm
Range	Range	Old Mandrel Part No.	New Mandrel Part No.	Part No.	Old Rough	New Rough	Old Med. Finish	New Med. Finish	Old Fine Finish	New Fine Finish	Old Steel Applications	New Steel Applications	Old Extra Fine Finish	New Extra Fine Finish				
.744-.781	18,9-19,8	4ML-750M*	4GP20750UA*	ST-750	ML-5	P20J25	ML-7	P20J47	ML-13	P20J67	ML-14	P20A69	ML-17	P20J85	UA-B	None	10	254
.775-.815	19,7-20,7	4ML-781M*	4GP20781UA*	ST-780	ML-5	P20J25	ML-7	P20J47	ML-13	P20J67	ML-14	P20A69	ML-17	P20J85	UA-B	None	10	254
.806-.843	20,5-21,4	4ML-812M*	4GP20812UB*	ST-812	ML-5	P20J25	ML-7	P20J47	ML-13	P20J67	ML-14	P20A69	ML-17	P20J85	UB-B	None	10	254
.838-.875	21,3-22,2	4ML-843M*	4GP20843UB*	ST-840	ML-5	P20J25	ML-7	P20J47	ML-13	P20J67	ML-14	P20A69	ML-17	P20J85	UB-B	None	10	254
.869-.906	22,1-23,0	5ML-875M*	5GP20875UB*	ST-875	ML-5	P20J25	ML-7	P20J47	ML-13	P20J67	ML-14	P20A69	ML-17	P20J85	UB-B	None	12.5	317
.900-.942	22,9-23,9	5ML-906M*	5GP20906UC*	ST-900	ML-5	P20J25	ML-7	P20J47	ML-13	P20J67	ML-14	P20A69	ML-17	P20J85	UC-B	None	12.5	317
.931-.968	23,6-24,6	5ML-937M*	5GP20937UC*	ST-937	ML-5	P20J25	ML-7	P20J47	ML-13	P20J67	ML-14	P20A69	ML-17	P20J85	UC-B	None	12.5	317
.962-1.003	24,4-25,5	5ML-968M*	5GP20968UC*	ST-960	ML-5	P20J25	ML-7	P20J47	ML-13	P20J67	ML-14	P20A69	ML-17	P20J85	UC-B	None	12.5	317
1.021-1.094	25,9-27,8	4PL-1031M*	4GP281000VA	ST-1031	PL-5	P28J27	PL-7	P28J47	PL-13	P28J67	PL-14	P28A69	PL-17	P28J85	VA-B	LN-1144	13	330
1.084-1.156	27,5-29,4	4PL-1094M*	4GP281062VA	ST-1094	PL-5	P28J27	PL-7	P28J47	PL-13	P28J67	PL-14	P28A69	PL-17	P28J85	VA-B	LN-1144	13	330
1.115-1.187	28,3-30,1	4PL-1125M*	4GP281125VB	ST-1125	PL-5	P28J27	PL-7	P28J47	PL-13	P28J67	PL-14	P28A69	PL-17	P28J85	VB-B	LN-1144	13	330
1.209-1.281	30,7-32,5	4PL-1219M*	4GP281187VB	ST-1219	PL-5	P28J27	PL-7	P28J47	PL-13	P28J67	PL-14	P28A69	PL-17	P28J85	VB-B	LN-1144	13	330
1.292-1.375	32,8-34,9	5PL-1312M*	5GP281250WB	ST-1300	PL-5	P28J27	PL-7	P28J47	PL-13	P28J67	PL-14	P28A69	PL-17	P28J85	WB-D	LN-1156	16.25	413
1.355-1.500	34,4-38,1	5PL-1375M*	5GP281375WC	ST-1375	PL-5	P28J27	PL-7	P28J47	PL-13	P28J67	PL-14	P28A69	PL-17	P28J85	WC-D	LN-1156	16.25	413
1.542-1.625	39,2-41,3	5PL-1562M*	5GP281500WD	ST-1562	PL-5	P28J27	PL-7	P28J47	PL-13	P28J67	PL-14	P28A69	PL-17	P28J85	WD-D	LN-1156	16.25	413
1.605-1.750	40,8-44,4	5PL-1625M*	5GP281625WD	ST-1600	PL-5	P28J27	PL-7	P28J47	PL-13	P28J67	PL-14	P28A69	PL-17	P28J85	WD-D	LN-1156	16.25	413
1.730-1.875	43,9-47,6	5PL-1750M	5GP281750WE	ST-1700	PL-5	P28J27	PL-7	P28J47	PL-13	P28J67	PL-14	P28A69	PL-17	P28J85	WE-D	LN-1156	16.25	413
1.855-2.000	47,1-50,8	5PL-1875M	5HP281875WE	ST-1875	PL-5	P28J27	PL-7	P28J47	PL-13	P28J67	PL-14	P28A69	PL-17	P28J85	WE-D	LN-1156	16.25	413
1.980-2.125	50,3-54,0	5PL-2000M	5HP282000WF	ST-2000	PL-5	P28J27	PL-7	P28J47	PL-13	P28J67	PL-14	P28A69	PL-17	P28J85	WF-D	LN-1156	16.25	413
2.105-2.250	53,5-57,1	5PL-2100M	5HP282125WE	ST-2125	PL-5	P28J27	PL-7	P28J47	PL-13	P28J67	PL-14	P28A69	PL-17	P28J85	WF-D	LN-1156	16.25	413
2.230-2.375	56,6-60,3	5PL-220v0M	5GP282250WF	ST-2200	PL-5	P28J27	PL-7	P28J47	PL-13	P28J67	PL-14	P28A69	PL-17	P28J85	WF-D	LN-1156	16.25	413
2.355-2.500	59,8-63,5	5PL-2375M	5HP282375WG	ST-2375	PL-5	P28J27	PL-7	P28J47	PL-13	P28J67	PL-14	P28A69	PL-17	P28J85	WG-D	LN-1156	16.25	413
2.480-2.625	63,0-66,7	5PL-2500M	5HP282500WG	ST-2500	PL-5	P28J27	PL-7	P28J47	PL-13	P28J67	PL-14	P28A69	PL-17	P28J85	WG-D	LN-1156	16.25	413

\*Requires the use of LN570A Concentric sleeve.

#### Notes:

- Allow for extra stock in new bushings to be sure honing unit will enter the hole.
- P20-J47 and P28-J47 medium finish stones are recommended for fitting king pins in one operation. If a large amount of stock must be removed, P20-J25 or P28-J27 stones may be used before finishing. Stone must be ordered separately.
- Quantity of stones and shoes required per honing unit is designated by the first digit of the honing unit part number. Example: 4G-P20-781UA has four shoes and four stones; 5G-P28-1250WB has five shoes and five stones.
- Replacement Tension Block (includes spring)  
For P20 Mandrels, part no. LN-1533A  
For P28 Mandrels up thru 5G-P28-1750WE, part no. LN-1336A  
For P28 Mandrels 5H-P28-1875WE and up, part no. LN-1337A
- Replacement Retainer Block  
For P20 Mandrels, part no. LN-1529A  
For P28 Mandrels up thru 5G-P28-1750WE, part no. LN-1329A  
For P28 Mandrels 5H-P28-1875WE and up, part no. LN-1330A
- Replacement Wedges  
For 4GP20 Mandrels, part no. 4G-P20  
For 5GP20 Mandrels, part no. 5G-P20  
For 4GP28 Mandrels, part no. 4G-P28  
For Mandrels 5G-P28-1250WB thru 5G-P28-1750WE, part no. 5G-P28  
For Mandrels 5H-P28-1875WE thru 5H-P28-2500WG, part no. 5H-P28

# Type CR Honing Units

## For Rod Reconditioning (Journal End)

**Range: 1.450"-4.700" (36,8-119,4 mm)**

These honing units will produce a round and straight rod bore and allow you to recondition the rod to original factory size, assuring a perfect fit of inserts.

### How to Order

Order LBN-62 Honing Unit Set for complete coverage of most popular cars and trucks. Covers diameters from 1.600" to 2.700" (36,8 to 68,6 mm).

OR

Order individual honing units as needed. Each unit is complete with wedge, wedge plates and shoes.

After cap and rod faces have been ground at right angles to the side of the rod to reduce the diameter of the bore, these honing units are used to bring the bore back to standard size.



### CR80A – Replacement eccentric ring

They are specially designed to remove stock from the reduced bore without enlarging the diameter across the parting line.

Honing Units			Replacement Parts					
①	②	For Complete Honing Unit Order	①	②	Shoe (2 per Pkg.)	Wedge Plate		Wedge
Range		Mandrel Part No.	Mandrel	Stones	Part No.	Part No.		Part No.
inches	mm					Large	Small	
1.450-1.600	36,8-40,6	CR-1450			CR-40D	Y44-HW	Y44-LW	CR-70
1.600-1.750	40,6-44,4	CR-1600*			CR-40D	Y44-HW	Y44-LW	CR-70
1.750-1.900	44,4-48,3	CR-1750*			CR-40D	Y44-HW	Y44-LW	CR-70
1.900-2.100	48,3-53,3	CR-1900*			CR-50D	CR-120	CR-110	CR-100
2.100-2.300	53,3-58,4	CR-2100*			CR-50D	CR-120	CR-110	CR-100
2.300-2.500	58,4-63,5	CR-2300*			CR-50D	CR-120	CR-110	CR-100
2.500-2.700	63,5-68,6	CR-2500*			CR-50D	CR-120	CR-110	CR-100
2.700-2.900	68,6-73,7	CR-2700			CR-50D	CR-120	CR-110	CR-200
2.900-3.100	73,7-78,7	CR-2900			CR-50D	CR-120	CR-110	CR-200
3.100-3.300	78,7-83,8	CR-3100			CR-50D	CR-120	CR-110	CR-200
3.300-3.500	83,8-88,9	CR-3300			CR-50D	CR-120	CR-110	CR-300A
3.500-3.700	88,9-94,0	CR-3500			CR-50D	CR-120	CR-110	CR-300A
3.700-3.900	94,0-99,1	CR-3700			CR-50D	CR-120	CR-110	CR-400A
3.900-4.100	99,1-104,1	CR-3900			CR-50D	CR-120	CR-110	CR-400A
4.100-4.300	104,1-109,2	CR-4100			CR-50D	CR-120	CR-110	CR-400A
4.300-4.500	109,2-114,3	CR-4300			CR-50D	CR-120	CR-110	CR-400A
4.500-4.700	114,3-119,4	CR-4500			CR-50D	CR-120	CR-110	CR-400A

Select From Chart Below

\*Included in Set LBN-62.

NOTE: Y44-LW was CR-75 and Y44-HW was CR-85, This is a Part-Number Change ONLY.

### Replacement Parts

#### Tension Block

LN-1685A—For CR-1450 thru CR-1750  
LN-1337A—For CR-1900 and up

#### Shoe Clamps

(Includes 4 clamps and screws)  
LN-1637A—For CR-1450 thru CR-1750  
CR-45A—For CR-1900 and up  
Includes CR-44A (pkg. 4 screws)

#### Bronze Shoes

For Power and Long Life (Manually Stroked Rod Reconditioning)

For CR-1450 thru CR-1750 Mandrels—order P/N PD-B

For CR-1900 thru CR-4500 Mandrels—order P/N CR-50B

### ② Stone Selection Chart

#### CR Stones for CR-1450 Thru CR-1750 Mandrels

CR-2	Medium Finishing
CR-4	Fine Finishing
Y44-J65	Aluminum Rods

#### CR Stones for CR-1900 Thru CR-4500 Mandrels

CR-9	Aluminum Rods/Titanium
CR-10	For Rough Honing, Manual Stroking
CR-10N	For Rough Honing, Power Stroking
CR-12	For Medium Finish Honing, Manual Stroking
CR-12-8	For Medium Finish Honing, Power Stroking
CR-14	For Fine Finish Honing, Manual Stroking

# All-Steel & Lifetime Honing Units

## For Connecting Rods (Pin Fitting)

Range: .619"-1.250" (15,7-31,7 mm)

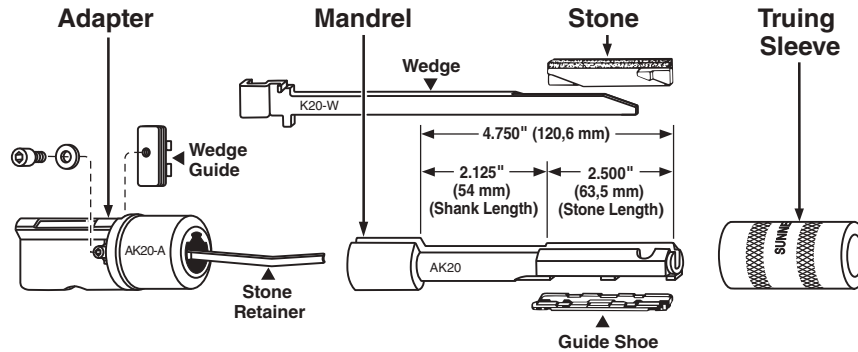

### For Con-Rod Bushings and Press-Fit Type Rods

All-steel and Lifetime Mandrels, specially made for fitting pins in con-rods. Stone and shoe are of proper length to produce straight, round, accurate holes. The all-steel mandrels (K-20) do not have replaceable shoes.

Part No.	Stones
K20J25	Roughing Stone for fast removal of stock in bronze bushings.
K20J47	Medium finishing stone for bronze and aluminum.
K20J67	Finishing stone for bronze and aluminum.
K20A69	Stones for honing press-fit type rods.

Part No.	Replacement Parts
K20-W	Replacement Wedge (Should be replaced when it begins to show wear.)
LN-3688A	Replacement Stone Retainer
LN-3218A	Replacement Wedge Guide

Notes: 1. Length of Honing Stone Surface – 2.5" (63,5 mm).  
2. Allow for extra stock in new bushings to be sure mandrel will enter the hole.

Note: Catalog part numbers referencing old and new are for inventory purposes only. Part is unchanged.

### Honing Units

For Complete Honing Unit Order		Mandrel (Includes K-20-W Wedge and Shoes)		Truing Sleeve	Adapter (Includes Retainer)	Stones (12 per Pkg.)				Replacement Guide Shoe (Included with Mandrels) 2 per Pkg.			
1	2	3	4			1	2	3	4				
Range		Old Mandrel Part No.	New Mandrel Part No.			Old Rough	New Rough	Old Finish	New Finish	Old Steel Applications	New Steel Applications	New Extra Fine Finish	
inches	mm												
<b>All-Steel Honing Units</b>													
.619-.650	15,7-16,5	KL-619M	K20619AS	S-619	K20-A	KL-5	K20J25	KL-13	K20J67	KL-14	K20A69	K20J85	None
.650-.680	16,5-17,3	KL-650M	K20650AS	S-650	K20-A	KL-5	K20J25	KL-13	K20J67	KL-14	K20A69	K20J85	None
.681-.712	17,3-18,1	KL-681M	K20681AS	S-681	K20-A	KL-5	K20J25	KL-13	K20J67	KL-14	K20A69	K20J85	None
.713-.743	18,1-18,9	KL-713M	K20713AS	S-713	K20-A	KL-5	K20J25	KL-13	K20J67	KL-14	K20A69	K20J85	None
<b>Lifetime Honing Units</b>													
.744-.774	18,9-19,7	KL-744M*	AK20744UA*	S-744*	AK-20A*	KL-5	K20J25	KL-13	K20J67	KL-14	K20A69	K20J85	UA-B
.775-.805	19,7-20,4	KL-775M	AK20775UA	S-775	AK-20A	KL-5	K20J25	KL-13	K20J67	KL-14	K20A69	K20J85	UA-B
.806-.837	20,5-21,3	KL-806M	AK20806UB	S-806	AK-20A	KL-5	K20J25	KL-13	K20J67	KL-14	K20A69	K20J85	UB-B
.838-.868	21,3-22,0	KL-838M*	AK20838UB*	S-838*	AK-20A*	KL-5	K20J25	KL-13	K20J67	KL-14	K20A69	K20J85	UB-B
.869-.899	22,1-22,8	KL-869M	AK20869UB	S-869	AK-20A	KL-5	K20J25	KL-13	K20J67	KL-14	K20A69	K20J85	UB-B
.900-.930	22,9-23,6	KL-900M*	AK20900UC*	S-900*	AK-20A*	KL-5	K20J25	KL-13	K20J67	KL-14	K20A69	K20J85	UC-B
.931-.961	23,6-24,4	KL-931M*	AK20931UC*	S-931*	AK-20A*	KL-5	K20J25	KL-13	K20J67	KL-14	K20A69	K20J85	UC-B
.962-.993	24,4-25,2	KL-962M*	AK20962UC*	S-962*	AK-20A*	KL-5	K20J25	KL-13	K20J67	KL-14	K20A69	K20J85	UC-B
.994-1.062	25,2-27,0	KL-1000M*	AK201000UD*	S-994*	AK-20A*	KL-5	K20J25	KL-13	K20J67	KL-14	K20A69	K20J85	UD-B
1.056-1.125	26,8-28,6	KL-1062M*	AK201062UD*	S-1062*	AK-20A*	KL-5	K20J25	KL-13	K20J67	KL-14	K20A69	K20J85	UD-B
1.119-1.187	28,4-30,1	KL-1125M*	AK201125UE*	S-1125*	AK-20A*	KL-5	K20J25	KL-13	K20J67	KL-14	K20A69	K20J85	UE-B
1.181-1.250	30,0-31,7	KL-1187M*	AK201187UE*	S-1187*	AK-20A*	KL-5	K20J25	KL-13	K20J67	KL-14	K20A69	K20J85	UE-B

\*Included in LBN-64 Set.

# Lifetime Honing Units

## For Connecting Rods (Pin Fitting)

**Range: .990"-2.625"**  
(25,1-66,7 mm)

**For:**

- Pin fitting in con-rods over 1.000" (25,4 mm).
- Small cylinders in motorcycles, lawn mowers, outboard motors, etc.

Mandrel does not wear...shoes are replaceable.

**Notes:**

1. Length of Honing Stone Surface—3.2812" (81,7 mm).
2. Allow for extra stock in new bushings to be sure honing unit will enter the hole.

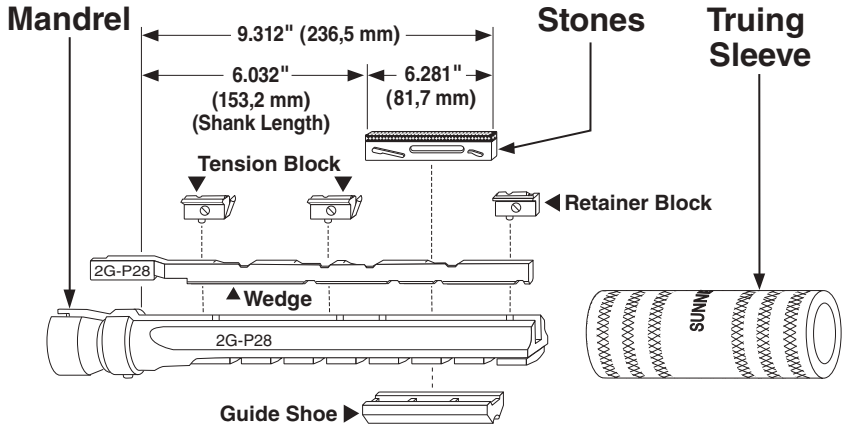

Note: Catalog part numbers referencing old and new are for inventory purposes only. Part is unchanged.

### Honing Units

For Complete Honing Unit Order		Mandrel (Includes Wedge and Shoes)		Truing Sleeve	Stones PL-Type (12 per Pkg.)										Replacement Parts (Included with Mandrel)		
1	2	3	1	2	3										Shoe (2 per Pkg.)	Shim Sets	Wedge
Range		Old Mandrel Part No.	New Mandrel Part No.	Part No.	Old Rough	New Rough	Old Med. Finish	New Med. Finish	Old Fine Finish	New Fine Finish	Old Steel Applications	New Steel Applications	Old Extra Fine Finish	New Extra Fine Finish			
inches	mm																
.990-1.062	25,1-27,0	1PL-1000M*	2GP281000VA*	ST-1000	PL-5	P28J27	PL-7	P28J47	PL-13	P28J67	PL-14	P28A69	PL-17	P28J85	VA-B	LN-1144	2G-P28
1.052-1.125	26,7-28,6	1PL-1062M*	2GP281062VA*	ST-1062	PL-5	P28J27	PL-7	P28J47	PL-13	P28J67	PL-14	P28A69	PL-17	P28J85	VA-B	LN-1144	2G-P28
1.115-1.187	28,3-30,1	1PL-1125M*	2GP281125VB*	ST-1125	PL-5	P28J27	PL-7	P28J47	PL-13	P28J67	PL-14	P28A69	PL-17	P28J85	VB-B	LN-1144	2G-P28
1.177-1.250	29,9-31,7	1PL-1187M*	2GP281187VB*	ST-1187	PL-5	P28J27	PL-7	P28J47	PL-13	P28J67	PL-14	P28A69	PL-17	P28J85	VB-B	LN-1144	2G-P28
1.230-1.375	31,2-34,9	1PL-1250M*	2GP281250WB*	ST-1250	PL-5	P28J27	PL-7	P28J47	PL-13	P28J67	PL-14	P28A69	PL-17	P28J85	WB-D	LN-1156	2G-P28
1.355-1.500	34,4-38,1	1PL-1375M*	2GP281375WC*	ST-1375	PL-5	P28J27	PL-7	P28J47	PL-13	P28J67	PL-14	P28A69	PL-17	P28J85	WC-D	LN-1156	2G-P28
1.480-1.625	37,6-41,3	1PL-1500M*	2GP281500WD*	ST-1500	PL-5	P28J27	PL-7	P28J47	PL-13	P28J67	PL-14	P28A69	PL-17	P28J85	WD-D	LN-1156	2G-P28
1.605-1.750	40,8-44,4	1PL-1625M*	2GP281625WD*	ST-1600	PL-5	P28J27	PL-7	P28J47	PL-13	P28J67	PL-14	P28A69	PL-17	P28J85	WD-D	LN-1156	2G-P28
1.730-1.875	43,9-47,6	1PL-1750M	2GP281750WE	ST-1700	PL-5	P28J27	PL-7	P28J47	PL-13	P28J67	PL-14	P28A69	PL-17	P28J85	WE-D	LN-1156	2G-P28
1.855-2.000	47,1-50,8	1PL-1875M	2HP281875WE	ST-1875	PL-5	P28J27	PL-7	P28J47	PL-13	P28J67	PL-14	P28A69	PL-17	P28J85	WE-D	LN-1156	2H-P28
1.980-2.125	50,3-54,0	1PL-2000M	2HP282000WF	ST-2000	PL-5	P28J27	PL-7	P28J47	PL-13	P28J67	PL-14	P28A69	PL-17	P28J85	WF-D	LN-1156	2H-P28
2.105-2.250	53,5-57,1	1PL-2125M	2HP282125WF	ST-2100	PL-5	P28J27	PL-7	P28J47	PL-13	P28J67	PL-14	P28A69	PL-17	P28J85	WF-D	LN-1156	2H-P28
2.230-2.375	56,6-60,3	1PL-2250M	2HP282250WF	ST-2200	PL-5	P28J27	PL-7	P28J47	PL-13	P28J67	PL-14	P28A69	PL-17	P28J85	WF-D	LN-1156	2H-P28
2.355-2.500	59,8-63,5	1PL-2375M	2HP282375WG	ST-2375	PL-5	P28J27	PL-7	P28J47	PL-13	P28J67	PL-14	P28A69	PL-17	P28J85	WG-D	LN-1156	2H-P28
2.480-2.625	63,0-66,7	1PL-2500M	2HP282500WG	ST-2500	PL-5	P28J27	PL-7	P28J47	PL-13	P28J67	PL-14	P28A69	PL-17	P28J85	WG-D	LN-1156	2H-P28

\*Requires eccentric sleeve LN-0116A. Note: See next page for Tension Block and Retainer Block Part Numbers.

## PHT Plateau Honing Tool

For Use With PL Mandrels

Tool	For Diameter Range	Abrasive Sets (320 GRIT)
PL Style Mandrels	.990-6.00" (25,146-152,4 mm)	P28-PHT-731 (fits all PL style mandrels)

## For Blind Hole Work...

The honing units listed above can be converted by ordering: **A** and **B**

A Wedge			B Stone						
Old Mandrel No.	New Mandrel No.	Order Wedge No.	For Honing	Old Rough	New Rough	Old Finish	New Finish	Old Polish	New Polish
1PL-1000M to 1PL-1750M	2GP281000VA- 2GP281750WE	2G-R28	Steel	RL-8	R28A49	RL-14	R28A65	RL-17	R28J85
1PL-1875M to 1PL-2500M	2HP281875WE- 2HP282500WG	2H-R28	Cast iron, Bronze, Aluminum	RL-7	R28J47	RL-13	R28J67	RL-17	R28J85

Note: Special short length hard tip stones and shoes available for honing short wheel cylinders. Call customer service department.

# Lifetime Honing Units

## For Piston Pin Fittings

**Range: .744"-2.625" (18,9-66,7 mm)**

Recommended for fast, accurate piston pin fitting. Especially for truck, tractor and diesel engines.

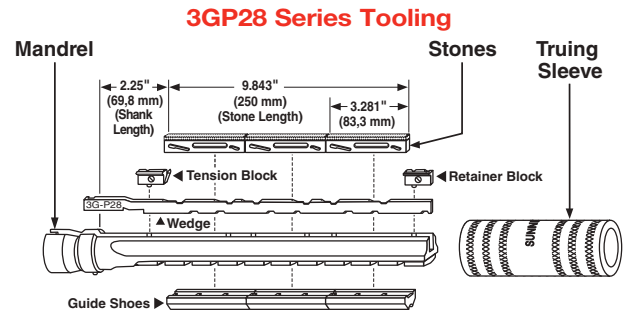
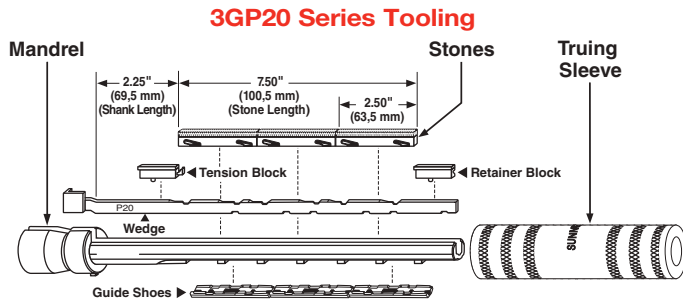

Note: Catalog part numbers referencing old and new are for inventory purposes only. Part is unchanged.

### Honing Units

For Complete Honing Unit Order		Mandrel (Includes Wedge and Shoes)		Truing Sleeve	Stones PL-Type (12 per Pkg.)										Replacement Parts (Included with Mandrel)	
Range		Old Mandrel Part No.	New Mandrel Part No.	Part No.	Old Rough	New Rough	Old Med. Finish	New Med. Finish	Old Fine Finish	New Fine Finish	Old Steel Applications	New Steel Applications	Old Extra Fine Finish	New Extra Fine Finish	Shoe (2 per Pkg.)	Shim Sets
.744-.781	18,9-19,8	3ML-750M*	<b>3GP20750UA*</b>	ST-750	ML-5	P20J25	ML-7	P20J47	ML-13	P20J67	ML-14	P20A69	ML-17	P20J85	UA-B	None
.775-.812	19,7-20,6	3ML-781M*	<b>3GP20781UA*</b>	ST-780	ML-5	P20J25	ML-7	P20J47	ML-13	P20J67	ML-14	P20A69	ML-17	P20J85	UA-B	None
.806-.843	20,5-21,4	3ML-812M*	<b>3GP20812UB</b>	ST-812	ML-5	P20J25	ML-7	P20J47	ML-13	P20J67	ML-14	P20A69	ML-17	P20J85	UB-B	None
.838-.875	21,3-22,2	3ML-843M*	<b>3GP20843UB*</b>	ST-840	ML-5	P20J25	ML-7	P20J47	ML-13	P20J67	ML-14	P20A69	ML-17	P20J85	UB-B	None
.869-.906	22,1-23,0	3ML-875M*	<b>3GP20875UB*</b>	ST-875	ML-5	P20J25	ML-7	P20J47	ML-13	P20J67	ML-14	P20A69	ML-17	P20J85	UB-B	None
.900-.937	22,9-23,9	3ML-906M*	<b>3GP20906UC*</b>	ST-900	ML-5	P20J25	ML-7	P20J47	ML-13	P20J67	ML-14	P20A69	ML-17	P20J85	UC-B	None
.931-.968	23,6-24,6	3ML-937M*	<b>3GP20937UC*</b>	ST-937	ML-5	P20J25	ML-7	P20J47	ML-13	P20J67	ML-14	P20A69	ML-17	P20J85	UC-B	None
.962-1.000	24,4-25,4	3ML-968M*	<b>3GP20968UC*</b>	ST-960	ML-5	P20J25	ML-7	P20J47	ML-13	P20J67	ML-14	P20A69	ML-17	P20J85	UC-B	None
.990-1.062	25,1-27,0	3PL-1000M*	<b>3GP281000VA*</b>	ST-1000	PL-5	P28J27	PL-7	P28J47	PL-13	P28J67	PL-14	P28A69	PL-17	P28J85	VA-B	LN-1144
1.052-1.125	26,7-28,6	3PL-1062M*	<b>3GP281062VA</b>	ST-1062	PL-5	P28J27	PL-7	P28J47	PL-13	P28J67	PL-14	P28A69	PL-17	P28J85	VA-B	LN-1144
1.115-1.187	28,3-30,1	3PL-1125M*	<b>3GP281125VB*</b>	ST-1125	PL-5	P28J27	PL-7	P28J47	PL-13	P28J67	PL-14	P28A69	PL-17	P28J85	VB-B	LN-1144
1.177-1.250	29,9-31,7	3PL-1187M*	<b>3GP281187VB*</b>	ST-1187	PL-5	P28J27	PL-7	P28J47	PL-13	P28J67	PL-14	P28A69	PL-17	P28J85	VB-B	LN-1144
1.230-1.375	31,2-34,9	3PL-1250M*	<b>3GP281250WB*</b>	ST-1250	PL-5	P28J27	PL-7	P28J47	PL-13	P28J67	PL-14	P28A69	PL-17	P28J85	WB-D	LN-1156
1.355-1.500	34,4-38,1	3PL-1375M*	<b>3GP281375WC*</b>	ST-1375	PL-5	P28J27	PL-7	P28J47	PL-13	P28J67	PL-14	P28A69	PL-17	P28J85	WC-D	LN-1156
1.480-1.625	37,6-41,3	3PL-1500M*	<b>3GP281500WD*</b>	ST-1500	PL-5	P28J27	PL-7	P28J47	PL-13	P28J67	PL-14	P28A69	PL-17	P28J85	WD-D	LN-1156
1.605-1.750	40,8-44,4	3PL-1625M*	<b>3GP281625WD*</b>	ST-1600	PL-5	P28J27	PL-7	P28J47	PL-13	P28J67	PL-14	P28A69	PL-17	P28J85	WD-D	LN-1156
1.730-1.875	43,9-47,6	3PL-1750M	<b>3GP281750WE</b>	ST-1700	PL-5	P28J27	PL-7	P28J47	PL-13	P28J67	PL-14	P28A69	PL-17	P28J85	WE-D	LN-1156
1.855-2.000	47,1-50,8	3PL-1875M	<b>3HP281875WE</b>	ST-1875	PL-5	P28J27	PL-7	P28J47	PL-13	P28J67	PL-14	P28A69	PL-17	P28J85	WE-D	LN-1156
1.980-2.125	50,3-54,0	3PL-2000M	<b>3HP282000WF</b>	ST-2100	PL-5	P28J27	PL-7	P28J47	PL-13	P28J67	PL-14	P28A69	PL-17	P28J85	WF-D	LN-1156
2.105-2.250	53,5-57,1	3PL-2125M	<b>3HP282125WF</b>	ST-2200	PL-5	P28J27	PL-7	P28J47	PL-13	P28J67	PL-14	P28A69	PL-17	P28J85	WF-D	LN-1156
2.230-2.375	56,6-60,3	3PL-2250M	<b>3HP282250WF</b>	ST-2250	PL-5	P28J27	PL-7	P28J47	PL-13	P28J67	PL-14	P28A69	PL-17	P28J85	WF-D	LN-1156
2.355-2.500	59,8-63,5	3PL-2375M	<b>3HP282375WG</b>	ST-2375	PL-5	P28J27	PL-7	P28J47	PL-13	P28J67	PL-14	P28A69	PL-17	P28J85	WG-D	LN-1156
2.480-2.625	63,0-66,7	3PL-2500M	<b>3HP282500WG</b>	ST-2500	PL-5	P28J27	PL-7	P28J47	PL-13	P28J67	PL-14	P28A69	PL-17	P28J85	WG-D	LN-1156

\*Requires eccentric sleeve LN-0116A. Included in LBN-11 Mandrel Set. See page 14.

#### Notes:

1. Allow for extra stock in new bushings to be sure honing unit will enter the hole.
2. For other Honing Stones, see pages 29 and 30.
3. Replacement Wedge—For P20 Mandrels, Part No. 3G-P20. For Mandrels 3G-P28-1000VA through 3G-P28-1750WE, Part No. 3G-P28. For Mandrels 3H-P28-1875WE up, Part No. 3H-P28.

4. Replacement Tension Block (Includes Spring)—For P20 Mandrels, Part No. LN-1533A. For Mandrels 3G-P28-1000VA through 3G-P28-1750WE, Part No. LN-1336A. For Mandrels 3H-P28-1875WE up, Part No. LN-1337A.
5. Replacement Retainer Block—For P20 Mandrels, Part No. LN-1529A. For Mandrels 3G-P28-1000VA through 3G-P28-1750WE, Part No. LN-1329A. For Mandrels 3H-P28-1875WE up, Part No. LN-1330A.

# All-Steel Honing Units

## Tooling Required For Honing High Performance Slotted Pistons

Type YY24 Mandrels are all-steel honing units. They are applicable to the honing of import and small domestic pistons and performance pistons with small diameter pins, with slotted piston pin bores.

For a Complete Honing Unit Order Mandrel, Truing Sleeve, Stone and Adapter.

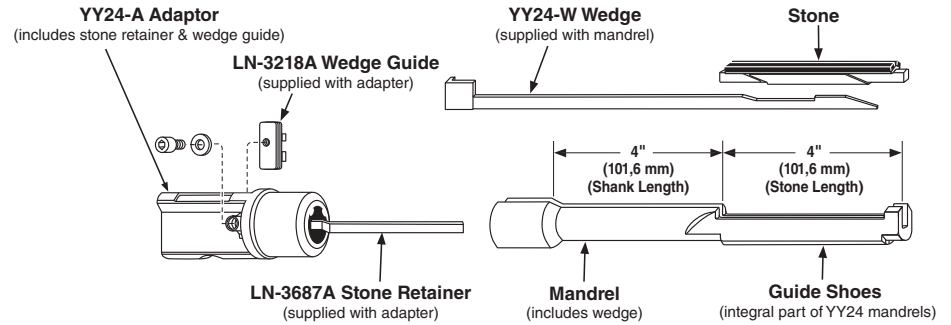

For Complete Honing Unit Order		Honing Units				
		①	②	③	④ (1 per Pkg.)	
Range		Mandrel Part No.	Sleeve	Adapter	Stone	Wedge
inches	mm					
.748-.758	19,0-19,35	<b>YY24-748M</b>	ST-750	YY24-A	YY24-J65	YY24-W
.787-.797	19,9-20,2	<b>YY24-787M</b>	ST-780	YY24-A	YY24-J65	YY24-W
.800-.810	20,3-20,5	<b>YY24-800M</b>	ST-800	YY24-A	YY24-J65	YY24-W
.826-.836	20,9-21,3	<b>YY24-826M</b>	ST-826	YY24-A	YY24-J65	YY24-W
.867-.877	22,0-22,3	<b>YY24-867M</b>	ST-867	YY24-A	YY24-J65	YY24-W
.875-.885	22,2-22,5	<b>RYY-875M</b>	ST-875	Not Required	RYY-13	YY32-W
.901-.911	22,9-23,1	<b>RYY-901M</b>	ST-900		RYY-13	YY32-W
.912-.922	23,2-23,4	<b>RYY-912M</b>	ST-912		RYY-13	YY32-W
.927-.940	23,5-23,9	<b>SYY-927M</b>	ST-927		SYY-13	YY32-W
.975-.980	24,8-24,9	<b>SYY-973M</b>	ST-973		SYY-13	YY32-W
.990-1.000	25,1-25,4	<b>SYY-989M</b>	ST-989		SYY-13	YY32-W
1.040-1.050	26,4-26,7	<b>SYY-1040M</b>	ST-1040		SYY-13	YY32-W
1.094-1.104	27,8-28,0	<b>SYY-1094M</b>	ST-1094		SYY-13	YY32-W

Note: These honing units must be used within a range of .010" (0,25 mm) of the standard wrist pin diameter shown.

### Type RYY and SYY: For pistons with wide slots in pin hole

Type RYY and SYY Mandrels are long-wearing, all-steel units, made especially for pistons with wide slots in the piston pin holes. The mandrels have extra-wide guide shoes, and the honing stones have a double surface for bridging the wide slots.

#### Notes:

1. These honing units must be used within a range of .010" (0,25 mm) of the standard wrist pin diameter shown.
2. Use LN-0116A Eccentric Sleeve with these honing units. See page 16.
3. Honing units must be trued in prior to use.

# All-Steel Honing Units

## For Piston Pin Fittings

**Range: .370"-.713" (9,4-18,1 mm)**

### Especially useful on Foreign Cars and Small Tractors.

Long-wearing honing units for small piston pin holes, distributor bushings, small king pin bushings and similar holes within the range.

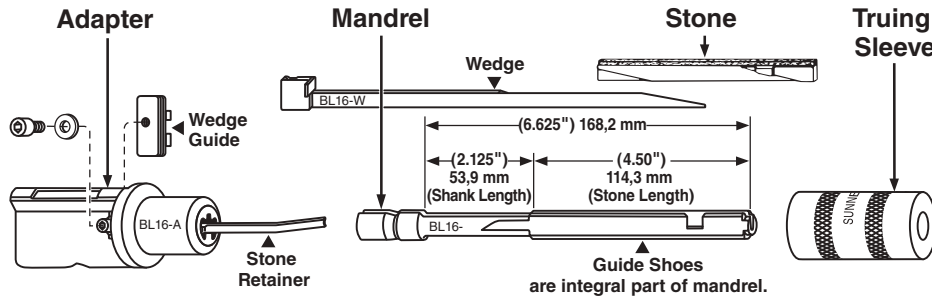

Note: Catalog part numbers referencing old and new are for inventory purposes only. Part is unchanged.

For Complete Honing Unit Order		Mandrel (Includes Wedge and Shoes)		Ship. Wt.		Truing Sleeve	Adapter (Includes Retainer)	Stones (6 per Pkg.)				Replacement Wedges
1	2	3	4	1	2	3	4	Old Rough	New Rough	Old Finish	New Finish	
Range		Old Mandrel Part No.	New Mandrel Part No.	lbs.	kg.							
inches	mm											
.370-.384	9,4- 9,8	LH-370M	<b>BL12370AS</b>	.25	,11	S-370	BL12-A	LH-7	L12J47	LH-13	L12J67	BL12-W
.432-.446	11,0-11,3	LH-432M	<b>BL12432AS</b>	.25	,11	S-432	BL12-A	LH-7	L12J47	LH-13	L12J67	BL12-W
.495-.525	12,6-13,3	LJ-495M*	<b>BL16495AS</b>	.5	,22	S-495	BL16-A	LJ-7	L16J47	LJ-13	L16J67	BL16-W
.526-.557	13,4-14,1	LJ-526M*	<b>BL16526AS</b>	.5	,22	S-526	BL16-A	LJ-7	L16J47	LJ-13	L16J67	BL16-W
.557-.587	14,1-14,9	LJ-557M*	<b>BL16557AS</b>	.5	,22	S-557	BL16-A	LJ-7	L16J47	LJ-13	L16J67	BL16-W
.619-.650	15,7-16,5	LJ-619M*	<b>BL20619AS</b>	.5	,22	S-619	BL20-A	LJ-7	L20J47	LJ-13	L20J67	BL16-W
.650-.681	16,5-17,3	LJ-650M	<b>BL20650AS</b>	.5	,22	S-650	BL20-A	LJ-7	L20J47	LJ-13	L20J67	BL16-W
.681-.713	17,3-18,1	LJ-681M*	<b>BL20681AS</b>	.5	,22	S-681	BL20-A	LJ-7	L20J47	LJ-13	L20J67	BL16-W

\*Included in LBN-1A. Note: Allow for extra stock in new bushings to be sure honing unit will enter hole.

### Bushing Expander

For expanding new bushings in rods...provides another use for your versatile Sunnen Honing Machine!

- Assures 100% contact for perfect heat transfer.
- Additional protection for your pin fit.
- Squeezes bushing into every hole irregularity.
- Swedges bushings in minutes.
- Trims bushing edges square and clean.



Pressed-in bushing touches on the high spots only.

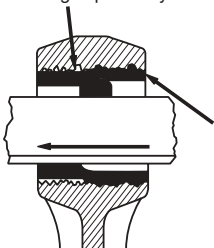

Expanded bushing fills in valleys and is locked in perfectly to rod eye.

Keeps bushings from working loose.

### Order

Expander Mandrel	1 Diameter Range		2 Expander (includes facing cutter)
	inches	mm	
ALR-720**	.720-.840	18,3-21,3	AL-12*
ALR-840**	.840-.900	21,3-22,9	AL-12*
ALR-900**	.900-.960	22,9-24,4	AL-12*
ALR-960**	.960-1.080	24,4-27,4	AL-12*

### SL-15 Roughing Cutter (Optional)



Used with the ALR series expander mandrels. It is used to remove excess bushing stock prior to honing.

AL54 Wedge (Replacement)

### Replacement Parts for AL-12



AL-144 Facing Cutter      AL-143A Expander Bit & Spring

\*ALR expander mandrels cannot be used without AL-12 expanders. Please order separately.

\*\*ALR mandrels require the use of AK20A adapter.

# Mandrel Sets

## For Pin Fitting and Rod Reconditioning

### Sunnen Mandrel Sets and Honing Unit Sets

The easy way to order. Buying in sets, using a single part number, simplifies ordering and assures having the right unit needed for the job at hand. Each set covers a particular size range or application.

#### LBN-1A All-Steel Honing Unit Set

For Small Diameters. Long wearing all-steel honing units for small piston pin holes— distributor bushings, small king pin bushings, and similar holes within the range. Includes L16J57 Roughing and L16J67 Finishing Stones. See page 13 for individual units.



Note: Catalog part numbers referencing old and new are for inventory purposes only. Part is unchanged.

#### Range: .495"-.713" (12,6 mm-18,1 mm)

Qty.	Old Part No.	New Part No.	Description	Qty.	Part No.	Description
1	LJ-495M	<b>BL16495AS</b>	Mandrel	1	<b>S-495</b>	Truing Sleeve
1	LJ-526M	<b>BL16526AS</b>	Mandrel	1	<b>S-526</b>	Truing Sleeve
1	LJ-557M	<b>BL16557AS</b>	Mandrel	1	<b>S-557</b>	Truing Sleeve
1	LJ-619M	<b>BL20619AS</b>	Mandrel	1	<b>S-619</b>	Truing Sleeve
1	LJ-681M	<b>BL20681AS</b>	Mandrel	1	<b>S-681</b>	Truing Sleeve
3	BL16-A	<b>BL16-A</b>	Adapters	1	<b>SL-30</b>	Mandrel Rack
2	BL18-A	<b>BL20-A</b>	Adapters			
6	LJ-7	<b>L16J47</b>	Stones			
6	LJ-13	<b>L16J67</b>	Stones			

Shipping Weight: 20 lbs. (9,1 kg)

#### LBN-11 Mandrel Set

For Piston Pin Fitting.

Contains four (4) mandrels, truing sleeves and medium finishing stones for piston pin fitting and general work within the size range shown. Mandrels are assembled with stones. See page 11 for additional units. For convenient storage order SL-38 Mandrel Rack separately. See page 16.



Note: Catalog part numbers referencing old and new are for inventory purposes only. Part is unchanged.

#### Range: .900"-1.062" (22,9 mm-26,9 mm)

Qty.	Old Part No.	New Part No.	Description	Qty.	Part No.	Description
1	3ML-906M	<b>3GP20906UC</b>	Mandrel	1	ST-900	Truing Sleeve
1	3ML-937M	<b>3GP20937UC</b>	Mandrel	1	ST-937	Truing Sleeve
1	3ML-968M	<b>3GP20968UC</b>	Mandrel	1	ST-960	Truing Sleeve
1	3PL-1000M	<b>3GP281000VA</b>	Mandrel	1	ST-1000	Truing Sleeve
12	ML-7	<b>P20J47</b>	Stones			
12	PL-7	<b>P28J47</b>	Stones			

Shipping Weight: Approx. 19 lbs. (8,6 kg)

### LBN-62 Lifetime Honing Unit Set



For Con Rod Reconditioning. A set of complete lifetime honing units for most popular cars and trucks. Covers diameters from 1.600"-2.700". Comes with CR-2 and CR-12 Stones for honing journal end of con rods. See page 8 for individual units.

#### Range: 1.600"-2.700" (40,6 mm-68,1 mm)

Qty.	Part No.	Qty.	Part No.
1	<b>CR-1600</b>	1	<b>CR-2100</b>
1	<b>CR-1750</b>	1	<b>CR-2300</b>
1	<b>CR-1900</b>	1	<b>CR-2500</b>

Includes SL-37 Mandrel Rack, 2 CR-2 and 4 CR-12 Stones.  
Shipping Weight: 53 lbs. (24,1 kg)

### LBN-64 Lifetime Honing Unit Set



For Con Rod Bushings and Press-Fit Type Rods.

Contains nine (9) complete lifetime honing units designed for accuracy and speed in honing con rods. See page 9 for individual units. Set includes 12 K20J67 Stones, plus 12 K20A69 Stones for honing press-fit type rod forgings. For convenient storage, order SL-30 Mandrel Rack separately. See page 16.

Note: Catalog part numbers referencing old and new are for inventory purposes only. Part is unchanged.

#### Range: .744"-1.250" (18,9 mm-31,7 mm)

Qty.	Old Part No.	New Part No.	Description	Qty.	Part No.	Description
1	KL-744M	<b>AK20744UA</b>	Mandrel	1	S-744	Truing Sleeve
1	KL-838M	<b>AK20838UB</b>	Mandrel	1	S-838	Truing Sleeve
1	KL-900M	<b>AK20900UC</b>	Mandrel	1	S-900	Truing Sleeve
1	KL-931M	<b>AK20931UC</b>	Mandrel	1	S-931	Truing Sleeve
1	KL-962M	<b>AK20962UC</b>	Mandrel	1	S-962	Truing Sleeve
1	KL-1000M	<b>AK201000UD</b>	Mandrel	1	S-994	Truing Sleeve
1	KL-1062M	<b>AK201062UD</b>	Mandrel	1	S-1062	Truing Sleeve
1	KL-1125M	<b>AK201125UE</b>	Mandrel	1	S-1125	Truing Sleeve
1	KL-1187M	<b>AK201187UE</b>	Mandrel	1	S-1187	Truing Sleeve
12	KL-5	<b>K20J25</b>	Stones	9	AK20-A	Adapters
12	KL-13	<b>K20J67</b>	Stones			
12	KL-14	<b>K20A69</b>	Stones			

Shipping Weight: Approx. 29 lbs. (13,2 kg)



# Ring Sets for LBB-1660 & ML-4000



## For Rod Reconditioning on Power-Stroke Honing Machine and CRF-100 Manually Stroked Rod Fixture

Each CR-Type Honing Unit in the 1.450"-3.300" (36,9-84 mm) range requires a Ring Set for fixturing the rods in the machine.

Order: CRF-500 Ring Set Kit-Includes all rings for 1.600" to 2.700" (36,8 mm-68,6 mm) range, plus CRF-495 Metal Storage Case.

For Coolant Fed Rings 1,9" (48 mm) and above Order: CRF-6XXA (one per pack). See page 19.

To order individual ring sets in 1.450"-3.300" (36,9-84 mm) range, refer to chart below.

For Use With Honing Units	Honing Unit Range		Rings (2 Rings per Pkg.) Shipping Wt. 3 lbs. (1.4 kg)			Ring Sets (4 Rings per Set) Shipping Wt. 6 lbs. (2.7 kg)		
	inches	mm	Part No.	Range		Part No.	Range	
				inches	mm		inches	mm
CR-1450	1.450-1.600	36,9-41,6	CRF-145A	1.450-1.520	36,9-38,7	CRF-14	1.450-1.600	36,9-41,6
			CRF-152A	1.520-1.600	38,7-41,6			
CR-1600	1.600-1.750	41,6-44,9	CRF-160A	1.600-1.670	41,6-42,4	CRF-16*	1.600-1.750	41,6-44,9
			CRF-167A	1.670-1.750	42,4-44,9			
CR-1750	1.750-1.900	44,9-48,7	CRF-175A	1.750-1.820	44,9-46,2	CRF-17*	1.750-1.900	44,9-48,7
			CRF-182A	1.820-1.900	46,2-48,7			
CR-1900	1.9-2.1	48-53	CRF-519A	1.9-2.0	48-51	CRF-19*	1.9-2.1	48-53
			CRF-520A	2.0-2.1	51-53			
CR-2100	2.1-2.3	53-58	CRF-521A	2.1-2.2	53-56	CRF-21*	2.1-2.3	53-58
			CRF-522A	2.2-2.3	56-58			
CR-2300	2.3-2.5	58-63	CRF-523A	2.3-2.4	58-61	CRF-23*	2.3-2.5	58-63
			CRF-524A	2.4-2.5	61-63			
CR-2500	2.5-2.7	63-69	CRF-525A	2.5-2.6	63-66	CRF-25*	2.5-2.7	63-69
			CRF-526A	2.6-2.7	66-69			
CR-2700	2.7-2.9	69-74	CRF-527A	2.7-2.8	69-72	CRF-27	2.7-2.9	69-74
			CRF-528A	2.8-2.9	72-74			
CR-2900	2.9-3.1	74-79	CRF-529A	2.9-3.0	74-77	CRF-29	2.9-3.1	74-79
			CRF-530A	3.0-3.1	77-79			
CR-3100	3.1-3.3	79-84	CRF-531A	3.1-3.2	79-82	CRF-31	3.1-3.3	79-84
			CRF-532A	3.2-3.3	82-84			

CRF-495 Metal Storage Case stores up to 28 rings. Rings have own compartments for ease of selection and convenient storage.

\*Included in CRF-500 Ring Set Kit. CRF-541A — Set up disk (for stroker alignment).

## Manual Stroke Rod Fixture Kit

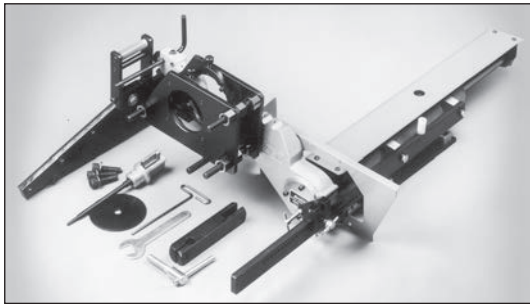

Order KKN-100, KKN-650 and MB-2410 for the Manual Stroke Rod Fixture Kit which provides controlled hand stroking:

- Rod bores are honed square with the face every time.
- Uniform "overstroking" on both ends of stones assures even wear, prolongs stone life, helps assure consistent crosshatch pattern.
- Reduces training time for operators.
- Can be factory installed when ordered with LBB-1660 or retrofitted in the field.

Note: Order CRF-500 RING SET KIT or individual ring sets separately.

# Sunnen Honing Machine Accessories

## Mandrel Storage Racks SL-30

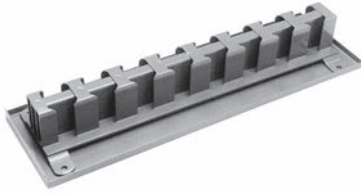

For types ALR, AK20, BL12, BL16 and BL20 Mandrels. Each rack holds 16 mandrels. Drain pan is included.  
*Shipping Weight: 5.5 lbs. (2,5 kg)*

## SL-38



For lifetime honing units with 1.5" (38,1 mm) diameter shank. Rack holds 8 units. Includes drain pan.  
*Shipping Weight: 5 lbs. (2,3 kg)*

## SL-37



For lifetime and rod reconditioning honing units with 1.75" (44,4 mm) diameter shank. Rack holds 7 units. Includes drain pan.  
*Shipping Weight: 5 lbs. (2,3 kg)*

## Touch Up Paint



Sunnen machine tool lacquer in 1 pint aerosol spray can.  
**MBB-90437A** Vista Green  
**MBC-90411A** Pearl Gray  
**MBC-90412A** Pewter Gray  
*Shipping Weight: 1 lb. (.45 kg)*

## Replacement Belts



For 6-Speed Heavy-Duty Floor Type Machine

Part No.	Description
<b>MBB-810</b>	Spindle Drive Belt
<b>MBB-820</b>	"V" Drive Belt
<b>MBB-880</b>	Honing Oil Pump Belt (for LBB-1499) 85.25" (2154 mm)
<b>MB-2292</b>	Honing Oil Pump Belt (for LBB-1660 and LBB-1699) 109" (2768 mm)

For LBB-1710 Power-Stroke Machine

Part No.	Description
<b>MBB-810</b>	Spindle Drive Belt
<b>MBB-820</b>	"V" Drive Belt
<b>MB-2292</b>	Honing Oil Pump Belt
<b>KKN-444A</b>	Stroker Belt

For LBB-1810 and LBC-1803 Power-Stroke Machines

Part No.	Description
<b>MBB-1830A</b>	Motor Drive Belt (60 Hz machines)
<b>MBB-1833A</b>	Motor Drive Belt (50 Hz machines)
<b>MBB-1840A</b>	Spindle Drive Belt
<b>KKN-444A</b>	Stroker Belt

*Shipping Weight: .5 lb. (.23 kg) each belt*

## LN-0116A Eccentric Sleeve



Adapts certain mandrels to machine spindle. Compensates for mandrel run-out. One required per machine.  
*Shipping Weight: 1 lb. (.45 kg)*

## MBC-200 Work Light



The MBC-200 is equipped with a 6-foot (1,83 meters) long cord with a 3-wire moulded-on grounding type plug. All pedestal or bench machines will accept the work light under either front spindle motor hold down bolt. Takes standard 110-volt, 100 watt bulb. Bulb not included.  
*Shipping Weight: 3.75 lbs. (1,7 kg)*

## CRF-750 Universal Holding Fixture

For LBB-1810 and LBC-1803 Honing Machines  
*Note: Can also be used on LBB-1660 Manual Hone equipped with CRF-100 Manual Stroked Rod Fixture.*



Accommodates most motorcycle and VW Cylinders and other parts within the CRF-750's range that can be placed on the honing machine. Fixture can be installed or removed quickly and easily. Takes thrust on forward and back strokes. Includes two pairs of fingers with long-wearing, adjustable carbide pads.  
*Shipping Weight: 6 lbs. (2,7 kg)*

## KKN-735A Torque Bracket Assembly



The KKN-735A is used in conjunction with the CRF-750 Universal Holding Fixture. It allows honing torque to be taken at the center of the bore length. It is especially useful for odd shaped cylinders typical of motorcycle applications.  
*Shipping Weight: 2.5 lbs. (1,13 kg)*

## MB-2333A Extra-Long Offset Torque Bar-23" (584 mm) Long



Useful for absorbing torque on workpieces which are too long for the standard 13" (330 mm) torque bar. Ideal for honing spindle bodies.  
*Shipping Weight: 4.5 lbs. (2,04 kg)*

# Sunnen Honing Machine Accessories

## CR-25 Chamfering Tool



Chamfers journal end of con-rods. Use in place of honing stone on Type CR-1900 and larger Honing Units. Carbide cutting tool has three cutting surfaces. Just flip cutter to new surface when cutting edge wears.

## CR-35 Chamfering Tool



Chamfers journal end of con-rods. Use in place of honing stone on Type CR-1450 thru CR-1750.

Replacement part CR-28A Carbide Cutter. Used for both CR-25 and CR-35.

## B-300 Countersink



For chamfering the wrist pin end of connecting rods. The B-300 Countersink includes an

adapter for chucking into the Sunnen Honing Machine and will chamfer bushed type as well as press-fit connecting rods. Chamfering the rod eyes makes assembling the wrist pin easier and eliminates the possibility of galling during installation. The unit is sold complete and ready for use in any Sunnen Honing Machine.

Range: .375" through 1.375" (9,5-34,9 mm) diameters.

Shipping Weight: 1.5 lbs. (.68 kg)

## MB-2410 Work Tray

For LBB-1660 and LBB-1699. Package of 2.



Attaches to left and right side of machine work tray. Keeps work area of machine free of parts while honing rods and pistons.

Shipping Weight: 13.5 lbs. (6,1 kg)

MB-2418A Replacement Pad for MB-2410 Tray. Package of one.

Shipping Weight: 1 lb. (.45 kg)

## LBN-700 Stone Dresser

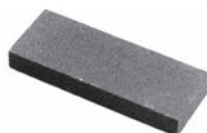

Helps keep honing stones sharp and cutting.

Shipping Weight: .25 lb. (.11 kg)

## LBN-462A Mandrel "T" Wrench

## LBN-730 Rod Support

Enables the operator to hone two V-6 or V-8 rods at the same time. Eases production problems associated with honing narrow connecting rods.

Shipping Weight: 6 lbs. (2,7 kg)



## MAN-700 Diamond Stone Dresser



When cutting action of honing stone slows down, a light stroke with the diamond dresser breaks the glaze and restores honing efficiency. Especially recommended for rod reconditioning. Consists of diamond stone on sturdy metal holder with chain for fastening to honing machine.

Shipping Weight: .5 lb. (.23 kg)

## AN-600 Honing Head

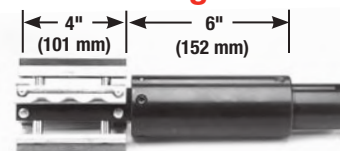

Diameter Range: 2.500"-6.500" (64 mm-165 mm).

Ideal for honing small engine, snowmobile and VW-type cylinders. Accuracy to .0005" (0,1 mm). Uses same stone sets as AN model Portable Cylinder Hone (see Page 42). Can be used with any pedestal model Sunnen Honing Machine.

Shipping Weight: 10 lbs. (4,5 kg)

## LN-150 2.5X Magnifying Glass

Ground optical glass. Excellent for inspecting the condition of carbide cutters, etc. Supplied in convenient leather case.

Shipping Weight: .25 lb. (.11 kg)



## Stone Chart for SL and UL Type Mandrels

For Use with Flow of Honing Oil

For Use with Mandrels	Roughing	Fine Finishing	Medium Finishing	Std. Pkg.	Ship. Wt. Lbs. Per Std. Pkg.	
					lbs.	kg
SL-480 thru SL-660 †	SL-1	SL-3		6	.5	.23
SL-720 and up †	SL-5	SL-13	SL-7	6	1.25	.57
	SL-8 ‡	SL-17**		6	1.25	.57
UL Type Mandrels †	UL-5	UL-13	UL-7	4	.75	.34

\*\* For extra-fine finishing.

† Mandrels are no longer manufactured. Stones are available until current stock is depleted.

‡ For honing steel.



# CRT Production Rod Reconditioning Tools

For Use With KGM-1000 Rod Reconditioning Machines

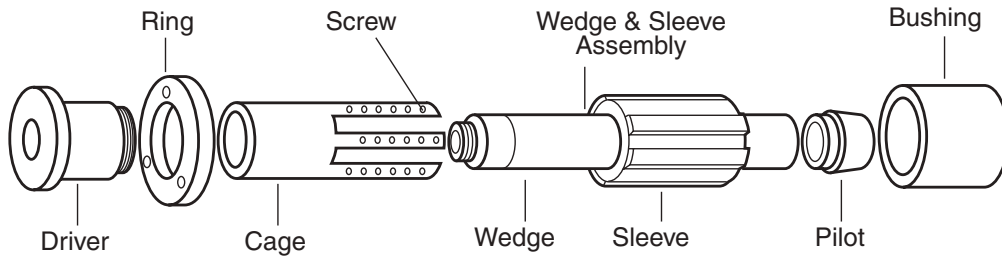

The tools listed in the following chart are the most commonly specified sizes. (Allow 2-4 weeks for processing.) Other sizes available on request. Consult your local Sunnen Field Engineer or Sunnen Customer Service toll-free in St. Louis.

Complete Tool Number*	Size Range Inches	Cage Number	New Sleeve and Wedge Assembly	Pilot Number	Screw Number	Alignment Bushing No.*
CRT68-2130-D5C	2.120-2.140	CRT68-C	CRT68-2130S-D5CA	CRT68-2130-P	PHSM-601	CRC-2120
CRT68-2230-D5C	2.220-2.240	CRT68-C	CRT68-2230S-D5CA	CRT68-2230-P	PHSM-601	CRC-2220
CRT72-2250-D5C	2.240-2.260	CRT72-C	CRT72-2250S-D5CA	CRT72-2250-P	PHSM-601	CRC-2240
CRT72-2280-D5C	2.270-2.290	CRT72-C	CRT72-2280S-D5CA	CRT72-2280-P	PHSM-601	CRC-2270
CRT72-2330-D5C	2.320-2.340	CRT72-C	CRT72-2330S-D5CA	CRT72-2330-P	PHSM-601	CRC-2330
CRT76-2380-D5C	2.370-2.390	CRT76-C	CRT76-2380S-D5CA	CRT76-2380-P	PHSM-601	CRC-2370
CRT76-2430-D5C	2.420-2.440	CRT76-C	CRT76-2430S-D5CA	CRT76-2430-P	PHSM-601	CRC-2420
CRT80-2500-D5C	2.490-2.510	CRT80-C	CRT80-2500S-D5CA	CRT80-2500-P	PHSM-602	CRC-2490

\*Alignment bushing not included with complete tool. Order separately.

## Replacement Sleeves

Replacement sleeves are available for all CRT tools. Customer MUST send old sleeve and wedge assembly to Sunnen Products for processing. Wedge and sleeve MUST remain as a matched set. Call Customer Service for additional information.



# SRT Production Rod Reconditioning Tools

For Use With ML and EC Series Machines



## SRT Stone Selections

Stone Set	SRT-1375	SRT-1500	SRT-1600	SRT-2000	SRT-2530	SRT-3000
<b>SRT00-XXXX</b>	1.37"-1.46" (34,8-37,1 mm)	—	—	—	—	—
<b>SRT0-XXXX</b>	1.44"-1.52" (36,6-38,6 mm)	—	—	—	—	—
<b>SRT1-XXXX</b>	1.50"-1.58" (38,1-40,1 mm)	1.50"-1.58" (38,1-40,1 mm)	1.57"-1.66" (39,9-42,2 mm)	1.97"-2.09" (50,0-53,1 mm)	2.50"-2.62" (63,5-66,5 mm)	2.97"-3.08" (75,4-78,2 mm)
<b>SRT2-XXXX</b>	1.58"-1.66" (40,1-42,2 mm)	1.58"-1.66" (40,1-42,2 mm)	1.65"-1.73" (41,9-43,9 mm)	2.05"-2.17" (52,1-55,1 mm)	2.58"-2.70" (65,5-68,6 mm)	3.05"-3.16" (77,5-80,3 mm)
<b>SRT3-XXXX</b>	1.66"-1.73" (42,2-43,9 mm)	1.66"-1.73" (42,2-43,9 mm)	1.73"-1.81" (43,9-46,0 mm)	2.13"-2.25" (54,1-57,2 mm)	2.66"-2.78" (67,6-70,6 mm)	3.13"-3.24" (79,5-82,3 mm)
<b>SRT4-XXXX</b>	—	1.74"-1.81" (44,2-46,0 mm)	1.81"-1.89" (46,0-48,0 mm)	2.21"-2.33" (56,1-59,2 mm)	2.74"-2.86" (69,6-72,6 mm)	3.21"-3.32" (81,5-84,3 mm)
<b>SRT5-XXXX</b>	—	1.82"-1.89" (46,2-48,0 mm)	1.89"-1.97" (48,0-50,0 mm)	2.29"-2.41" (58,2-61,2 mm)	2.82"-2.94" (71,6-74,7 mm)	3.29"-3.40" (83,6-86,4 mm)
<b>SRT6-XXXX</b>	—	1.90"-1.97" (48,3-50,0 mm)	1.97"-2.05" (50,0-52,1 mm)	2.37"-2.49" (60,2-63,2 mm)	2.90"-3.02" (73,7-76,7 mm)	3.37"-3.48" (85,6-88,4 mm)
<b>SRT7-XXXX</b>	—	1.98"-2.05" (50,3-52,1 mm)	2.05"-2.13" (52,1-54,1 mm)	2.45"-2.57" (62,2-65,3 mm)	2.98"-3.10" (75,7-78,7 mm)	3.45"-3.56" (87,6-90,4 mm)

XXXX = Order abrasive type and grit size from chart below.



## Abrasives

Diamond (D or R) & CBN (N) — Metal (M) Bond – 6 per Set

100	150	220	280	400	500	600
		DM55				DM05
					RMG97	
NMG37	NMG47	NMG55	NMG67	NMG85	NMG87	NMG47
						NMG47

Note: Abrasives are special order - call Automotive Customer Service for pricing and delivery times.

## AFX-1000 Production Rod Reconditioning Fixture

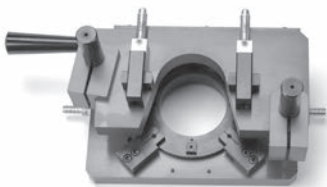

For use in Sunnen CGM, KGM, EC and ML type honing machines.

## Alignment Bushings

(Select bushings based on rod size)  
Available from stock

CRC-2120	CRC-2330
CRC-2220	CRC-2370
CRC-2240	CRC-2420
CRC-2270	CRC-2490

Note: For additional sizes call Automotive Customer Service for pricing and delivery times.

## AFX Ring and Finger Selections

Coolant ports supplied in these rings.



Part Diameter	Use with CRF Ring	Finger Part No.	Part Length
1.450"-1.520" (36-38 mm)	CRF-145NB2X	FX-318	2.039" (52 mm)
1.520"-1.600" (38-40 mm)	CRF-152NB2X	FX-319	2.004" (51 mm)
1.600"-1.670" (40-42 mm)	CRF-160NB2X	FX-320	1.964" (50 mm)
1.670"-1.750" (42-44 mm)	CRF-167NB2X	FX-321	1.929" (49 mm)
1.750"-1.820" (44-46 mm)	CRF-175NB2X	FX-322	1.889" (48 mm)
1.820"-1.900" (46-48 mm)	CRF-182NB2X	FX-323	1.854" (47 mm)
1.900"-2.000" (48-51 mm)	CRF-619A	FX-068	1.814" (46 mm)
2.000"-2.100" (51-53 mm)	CRF-620A	FX-069	1.764" (45 mm)
2.100"-2.200" (53-56 mm)	CRF-621A	FX-070	1.714" (44 mm)
2.200"-2.300" (56-58 mm)	CRF-622A	FX-071	1.664" (42 mm)
2.300"-2.400" (58-61 mm)	CRF-623A	FX-072	1.614" (41 mm)
2.400"-2.500" (61-63 mm)	CRF-624A	FX-073	1.564" (40 mm)
2.500"-2.600" (63-66 mm)	CRF-625A	FX-074	1.514" (38 mm)
2.600"-2.700" (66-68 mm)	CRF-626A	FX-075	1.464" (37 mm)
2.700"-2.800" (68-71 mm)	CRF-627A	FX-076	1.414" (36 mm)
2.800"-2.900" (71-74 mm)	CRF-628A	FX-077	1.364" (35 mm)
2.900"-3.000" (74-76 mm)	CRF-629A	FX-078	1.314" (33 mm)
3.000"-3.100" (76-79 mm)	CRF-630A	FX-079	1.264" (32 mm)
3.100"-3.200" (79-81 mm)	CRF-631A	FX-080	1.214" (31 mm)

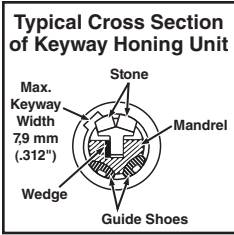

# Keyway Honing Units

## Y32 Keyway Honing Units Diameter Range: .992" - 1.375" (25,20 - 34,93 mm)

For honing parts with keyways,  
i.e.: harmonic balancers.

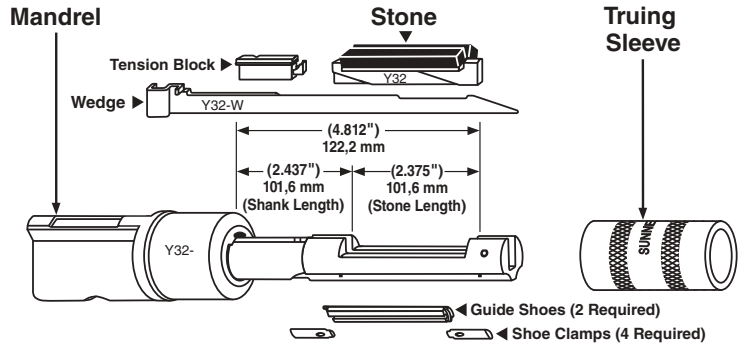

### Order 1-4 For Complete Y32 Keyway Honing Units

Diameter Range 25,20 mm - 34,93 mm .992" - 1.375"		① Y32 Mandrel Supplied with a Y32-A Adapter and Wedge	② Truing Sleeve	③ Alignment Bushing*  For machines with fully adjustable spindle nose	④ Honing Stone	Replacement Guide Shoes† (2 required)	
mm	inches					With Standard Shank	Bronze General Purpose Furnished with Mandrel
25,20-26,97	.992-1.062	Y32-1000PB	S-994	C-1000	See Chart Below	PB-B	PB-H
26,77-28,57	1.054-1.125	Y32-1062PB	S-1062	C-1062		PB-B	PB-H
28,37-30,15	1.117-1.187	Y32-1125PB	S-1125	C-1125		PB-B	PB-H
29,95-31,75	1.179-1.250	Y32-1187PC	S-1187	C-1187		PC-B	PC-H
31,55-33,32	1.242-1.312	Y32-1250PC	S-1250	C-1250		PC-B	PC-H
33,12-34,92	1.304-1.375	Y32-1312PC	S-1312	See note below*		PC-B	PC-H

\*Note: Alignment Bushing - Select the bushing whose bore diameter is just under finish size. When setting up the job for the first time, the undersize alignment bushing can be honed out to finish size with the same tooling used for honing the workpiece.

†Superabrasive Stone Inserted Guide Shoes for situations where a longer life shoe is needed.  
Contact Customer Service for ordering information. Available 4 weeks after receipt of order.

### Y32 Mandrel Replacement Parts

Part No.	Description
Y32-W	Wedge Replace when wear begins to show.
LN-1617A	Shoe Clamp Set For Mandrels with PB Suffix. 4 clamps with screws
LN-1627A	Shoe Clamp Set For Mandrels with PC Suffix. 4 clamps with screws
LN-1575A	Tension Block

### ④ Stone Selection Chart

Part No.	Description
Y32-A55	For Steel Applications
Y32-J67	For Bronze and Cast Iron Applications

Contact customer service for additional stone selections.

# Honing Oils & Coolants

## For Honing Connecting Rods on Sunnen Machines

### Mineral Base Honing Oil

CK-50-55 55 gal. drum

CK-50 is specially formulated for honing cast iron automotive and truck engine blocks and should not be used to hone other materials.



MAN-845-55 55 gal. drum

MAN-845-5 5 gal. pail

MAN-845 is formulated for general purpose automotive machine shop honing. Most commonly used.

MB-30-55 55 gal. drum

MB-30-5 5 gal. pail

MB-30 is Sunnen's multi-purpose industrial honing oil. MB-30 works on virtually any metal from aluminum to zirconium.

### MAN-C Honing Oil Concentrate

MAN-C is a honing oil concentrate, which when mixed at the proper ratios with customer supplied mineral oil, makes MAN-845 or CK-50 honing oil. The end user will save on shipping expenses by purchasing the mineral oil locally and mixing it with MAN-C at their facility.



### SCC-205 Water Base Coolant



SCC-205 honing coolant concentrate is formulated to meet the demands of metal bond superabrasive honing.

### SCC-605



SCC-605 honing coolant concentrate is formulated to meet the demands of metal bond superabrasive honing.

### SHO-965 Honing Oil

#### SPECIFICATIONS

Chemistry: Contains no mineral oil, sulfur, or chlorine

Viscosity: 25 cSt@40°C

Hazardous OSHA/DOT: No/No

VOC: 30 grams/liter

#### FEATURES & BENEFITS

- Low VOC, super-compliant in California's SCAQMD

SHO-965 is a high performance lubricant and multi-purpose industrial honing oil without the volatile organic compound content and without the odor.



### Filters



Sunnen PF Filters are designed to extend your oil and coolant life.

#### Replacement Filters

Part No.	Description
PF-105-4	Extra Fine Filter (oil only) (Pkg. of 4)
PF-110-4	Fine Filter (oil only) (Pkg. of 4)
PF-104	Extra Fine Filter (oil or water) (Pkg. of 1)
PF-160	Fine Filter (oil or water) (Pkg. of 1) (Fiberglass)

### SCC-900

#### SCC-900 Coolant Maintenance Kit

Poor housekeeping and improper coolant concentration are the major causes of coolant failure, yet simple daily maintenance will protect and prolong coolant life.

The Sunnen SCC-900 Coolant Maintenance Kit provides everything you will need to check water based coolant. Kit includes: Instruction and Record Forms, Refractometer, PH Kit, Pitcher Storage Case.

### Machine Capacities

LBB-1699 & LBB-1660

15 Gal. Capacity

LBB-1810 & LBB-1803

25 Gal. Capacity

EC-3500, ML-3500 and ML-5000

32 Gal. Capacity

ML-2000

28 Gal. Capacity

SV-20

75 Gal. Capacity

### B-200 Press Fit Lubricant

Prevents galling and reduces ram pressure. Twelve spray cans per package.



### B-200L

Same lubricant as B-200 except packaged in brush applicator bottle.





# DH-Series Diamond Honing System

**Multi-Point cutting action for a truly round bore!**

With multiple points of cutting action, Sunnen's DH Diamond Hone Head offers truly round cylinder bores – superior to any product on the market. Two designs of stones are offered - an economical one with 8 points of contact for rough boring applications or double 16 points for optimum bore tolerance.

No matter which model you chose, Sunnen's DH Hone Head uses a central drive shaft assembly. This design gives you the flexibility to change diameter ranges by simply switching the body and stone assembly. You can purchase the complete system or only the diameter range you need.

Sunnen offers the largest range of diamond hone heads in the industry - from 2.75 in. to 5.555 in. (69,9-141,1 mm). It is versatile, as well. You can use metal bond superabrasives and PHT plateau brushes. Sunnen's DH tooling, stones and holders are made as one which reduces initial truing time. With Sunnen's precision abrasives, there is no need to flip stones ... another time saver.

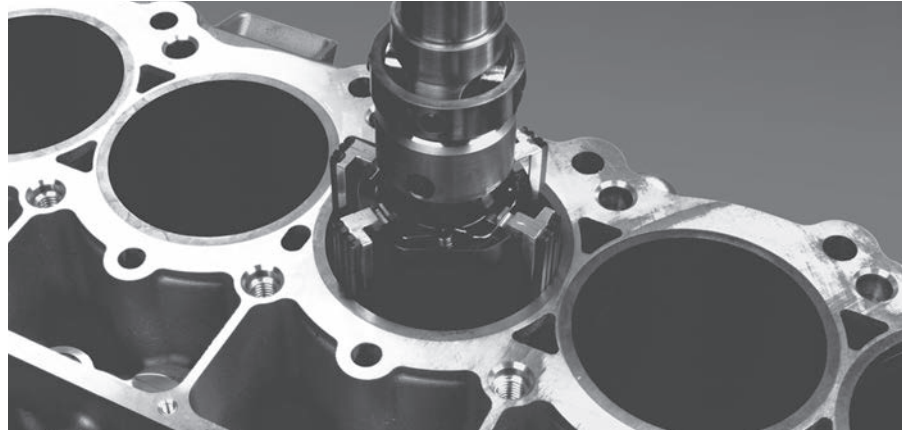

**4 Stone - 8 Cutting Edges**

**4 Stone - 16 Cutting Edges**

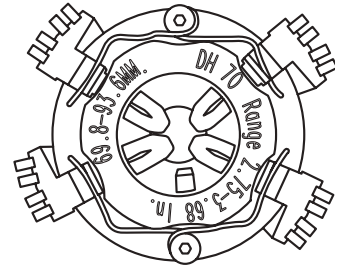
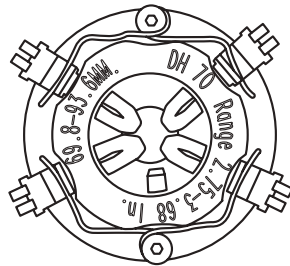

## Complete System for DHTKIT 2.75" - 5.55" (69,9 - 141,1 mm) Includes:

- ① DH-DA Drive shaft assembly
- ② DH-70 hone body
- ③ DH-93 hone body
- ④ DH-117 hone body

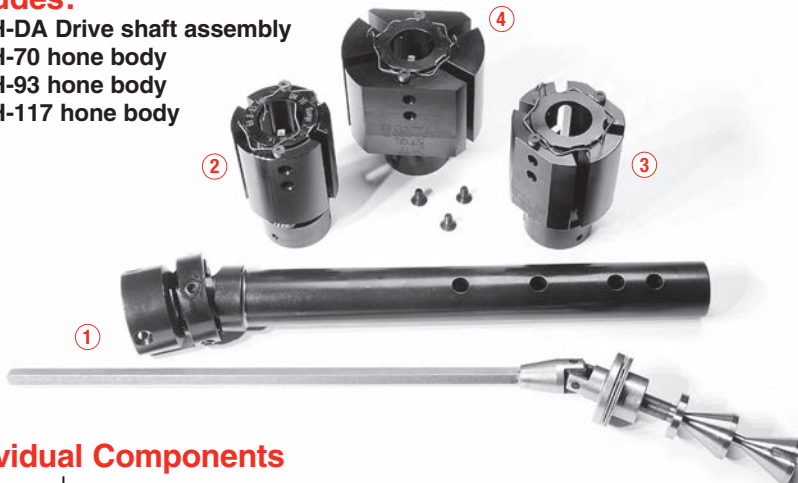

## Individual Components

Part No.	Description
DH-DA	Drive shaft assembly only. Common to all hone bodies.
DHT-70	Hone body and drive shaft. Range 2.75"–3.68" (69,85 - 93,47 mm)
DHT-93	Hone body and drive shaft. Range 3.68"–4.62" (93,47 - 117,34 mm)
DHT-117	Hone body and drive shaft. Range 4.62"–5.55" (117,34 - 141 mm)
DH-224	Stone retaining spring
DH-228A	Diamond dressing stick

## Optional accessories for industrial use:

DH-206 (drive shaft tube) and DH-207 (feed hex rod) are available to lengthen the standard DH-DA drive assembly from 13.5" to 24.5". (Requires stone assemblies shown in table.) High Force cone and stone assembly, see next page.



# DH Honing Tool

## Components and Abrasives

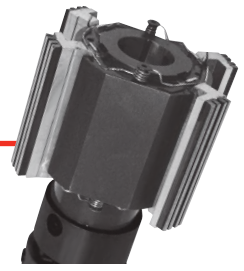

### DH Diamond Hone Head Size Ranges

Body	2-Stone	4-Stone	PHT Brush	Minimum		Maximum		Available Stones	Grit Size
				mm	inches	mm	inches		
DHT70	DH2S-1	N/A	DH1B-1-534	69,9	2.750	77,7	3.062	—	—
DHT70	DH2S-2	N/A	DH1B-2-534	77,7	3.062	85,7	3.374	NMH55	220
DHT70	DH2S-3	DH4S-3	DH1B-3-534	85,7	3.374	93,6	3.686	—	—
DHT93	DH2S-4	DH4S-4	DH1B-4-534	93,6	3.686	101,5	3.998	GMH45	150
DHT93	DH2S-5	DH4S-5	DH1B-5-534	101,5	3.998	109,5	4.310	GMH55	220
DHT93	DH2S-6	DH4S-6	DH1B-6-534	109,5	4.310	117,4	4.622	GMH75	320
DHT117	DH2S-7	DH4S-7	DH1B-7-534	117,4	4.622	125,3	4.933	GMH85	400
DHT117	DH2S-8	DH4S-8	DH1B-8-534	125,3	4.933	133,2	5.244	RMH95	500
DHT117	DH2S-9	DH4S-9	DH1B-9-534	133,2	5.244	141	5.555	RMH05	600

Order example: DH2S-1xxx (stone #), DH2S-1NMH55

Call Sunnen for additional stone availability.

### DHH Diamond Hone Head

High-force Feed Cone and stone sets. Check availability for difficult materials.

Item Number	Description
DH229	High-Force Feed Cone
DHH6	Diamond Stone Set (Range: 3.680"–3.880") (93, 47-98, 55 mm)
DHH7	Diamond Stone Set (Range: 3.880"–4.080") (98, 55-103, 63 mm)
DHH8	Diamond Stone Set (Range: 4.080"–4.280") (103, 63-108, 71 mm)
DHH9	Diamond Stone Set (Range: 4.280"–4.480") (108, 71-113, 79 mm)
DHH10	Diamond Stone Set (Range: 4.480"–4.680") (113, 79-118, 87 mm)
DHH11	Diamond Stone Set (Range: 4.680"–4.880") (118, 87-123, 95 mm)
DHH12	Diamond Stone Set (Range: 4.880"–5.080") (123, 95-129 mm)
DHHB-6534	PHT Brush Set (Range: 3.680"–3.880") (93, 47-98, 55 mm)
DHHB-7534	PHT Brush Set (Range: 3.880"–4.080") (98, 55-103, 63 mm)
DHHB-8534	PHT Brush Set (Range: 4.080"–4.280") (103, 63-108, 71 mm)
DHHB-9534	PHT Brush Set (Range: 4.280"–4.480") (108, 71-113, 79 mm)
DHHB-10534	PHT Brush Set (Range: 4.480"–4.680") (113, 79-118, 87 mm)
DHHB-11534	PHT Brush Set (Range: 4.480"–4.680") (113, 79-118, 87 mm)
DHHB-12534	PHT Brush Set (Range: 4.480"–4.680") (113, 79-118, 87 mm)

Note: GMH55, GMH75, RMH95 and RMH05 abrasive grades will be set up initially.

### Stone and Brush Options



**DH Stone 25**  
25 - acceptable roundness.

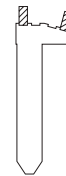

**DH Stone 2W**  
2W – good roundness, budget price

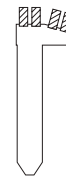

**DH Stone 4S**  
4S- superior or optimum roundness, more expensive. 4-stone will last longer, 16 cutting edges versus 8.



**Plateau PHT - Brush Options**  
Plateau PHT Brush are mounted on throwaway aluminum stone holders. For the DHT-70, DHT-93 & DHT-117 hone bodies, brush assemblies 1 through 9 offer 1 PHT brush mounted on each stone holder.



# SV-I0/20/400/2400/CV/CK Honing Machines

## Accessories and Supplies for CK-2000 Midget Hone Head Range: 2.000" to 3.000" I.D. (51 mm to 76 mm)

### Basic Parts

Diameter Range: 2"-3" (50,8-76,2 mm)

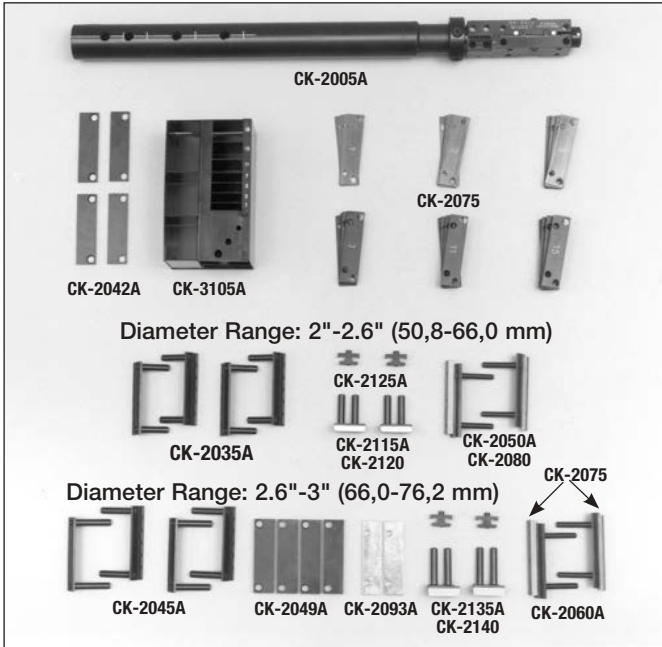

Diameter Range: 2"-2.6" (50,8-66,0 mm)

Diameter Range: 2.6"-3" (66,0-76,2 mm)

### CK-2075 Shim Kit



(Included with CK-2000 Hone Head)

Kit Includes:

Part No.	Qty.	Description
CK-2071A	2 sets	Guide & Stone #1
CK-2072A	2 sets	Guide & Stone #2
CK-2073A	2 sets	Guide & Stone #3
CK-2074A	1 set	Guide & Stone #7
CK-2076A	1 set	Guide & Stone #11
CK-2077A	1 set	Guide & Stone #15

(4 per set)

### CK-2000 Midget Hone Head Set

Part No.	Supplied with CK-2000	Description
CK-1823A	1	Tapered Locking Screw (Not shown)
CK-2005A	1	Midget Head and Tube Assembly
CK-2042A	4	Stone Shim, .125" (3,17 mm) (1 per package)
CK-3105A	1	Shim Rack
CK-2075	1 set	Guide Shim Set
CK-2035A	2 sets	Master Stoneholder Set (2 per set)
CK-2050A	2	Main and Centering Guides (Includes CK-2080)
CK-2080	-	Guide Shoe and Screw Set (2 shoes per set) (Included with C-2050A)
CK-2115A	1 set	Alignment Guide Set (2 per set) (Includes CK-2120)
CK-2120	-	Alignment Guide Shoe and Screw Set (2 shoes per set) (Included with CK-2115A)
CK-2125A	4	Clamp (1 per package)
CK-2045A	2 sets	Master Stoneholder Set (2 per set)
CK-2049A	2 sets	Stone Shim Set, .2812" (7,14 mm) (2 per set)
CK-2060A	2	Main and Centering Guides (Includes CK-2070)
CK-2070	1	1 Guide Shoe and 1 Screw Set (3 per set) (Included with CK-2060A)
CK-2135A	1 set	Alignment Guide Set (2 per set) (Includes CK-2140)
CK-2140	-	Alignment Guide Shoe and Screw Set (2 shoes per set) (Included with CK-2135A)
CK-2093A	2	Guide Shim .1875" (4,75 mm) (1 per package)

### Accessories

(Not included with CK-2000)

#### CK-2040A Midget Storage Rack

For orderly storage of Stoneholders and Alignment Guides.  
Shipping Weight: 3 lbs. (1,36 kg)



#### CK-3155A Setting Gage

Indicates shims required to set Guides and Stones to cylinder diameter. Also used to adjust Alignment Guides.  
Shipping Weight: 3.5 lbs. (1,59 kg) (Used also with CK-2600 and CK-3000 Hone Heads.)



#### CK-3355A Stone Inserter

Changes Stones easily in seconds. Includes mounting bracket.  
Shipping Weight: 7.5 lbs. (3,40 kg) (Used also with CK-2600 and CK-3000 Hone Heads.)



#### CK-3373A Spring Retainer

Holds the CK-3372 slide in position during stone insertion or removal.  
Also used on the CK-4355A inserter.



#### CK-2570 Hard Guide Shoe

For long life in high production shops.  
Shipping Weight: .5 lb. (.22 kg) (Not recommended with 400 grit or finer stone sets.)



# SV-I0/20/400/2400/CV/CK Accessories & Supplies

## CK-2600 Junior Hone Head

Range: 2.600" to 3.500" I.D. (66 mm to 89 mm)

### Basic Parts

Diameter Range: 2.6"-3.5" (66-89 mm)

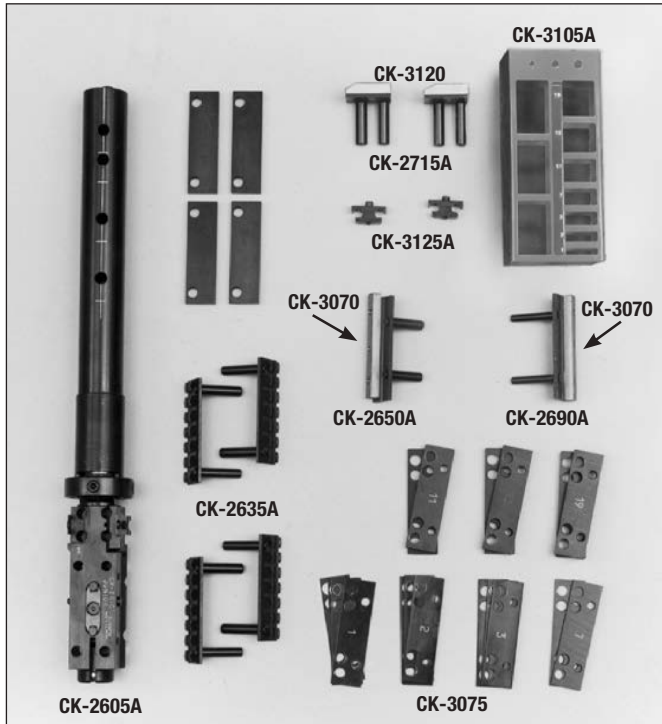

### CK-2600 Junior Hone Set

Part No.	Supplied with CK-2600	Description
CK-1823A	1	Tapered Locking Screw (Not shown)
CK-2605A	1	Junior Head and Tube Assembly
CK-3042A	4	Stone Shim, .25" (6,35 mm) (1 per package)
CK-2715A	1 set	Alignment Guide Set (2 per set) (Includes CK-3120)
CK-3120	-	Alignment Guide Shoe and Screw Set (2 shoes per set) (Included in CK-2715A)
CK-3125A	2	Clamp (1 per package)
CK-3105A	1	Shim Rack
CK-3075	1 set	Guide Shim Set
CK-2635A	2 sets	Master Stoneholder Set (2 per set)
CK-2650A	1	Main Guide (Includes CK-3070)
CK-3070	-	1 Guide Shoe and 1 Screw Set (Included in CK-2650A and CK-2690A)
CK-2690A	1	Centering Guide (Includes CK-3070)

### CK-3075 Shim Kit

(Included with CK-2600 Hone Head)



Kit Includes:

Part No.	Qty.	Description
CK-3071A	2 sets	Guide & Stone #1
CK-3072A	2 sets	Guide & Stone #2
CK-3073A	2 sets	Guide & Stone #3
CK-3074A	1 set	Guide & Stone #7
CK-3076A	1 set	Guide & Stone #11
CK-3077A	1 set	Guide & Stone #15
CK-3078A	1 set	Guide & Stone #19

(4 per set)

Applicable to CK-3000 and CK-2600 Hone Heads.

### Accessories

(Not included with CK-2600)

#### CK-3040A Standard Storage Rack

For orderly storage of Stoneholders and Alignment Guides.

Shipping Weight: 3.5 lbs. (1,59 kg)  
(Used also with CK-3000 Hone Head.)



#### CK-3155A Setting Gage

Indicates shims required to set Guides and Stones to cylinder diameter. Also used to adjust Alignment Guides.

Shipping Weight: 3.5 lbs. (1,59 kg)  
(Used also with CK-2000 and CK-3000 Hone Heads.)



#### CK-3355A Stone Inserter

Changes Stones easily in seconds. Includes mounting bracket.

Shipping Weight: 7.5 lbs. (3,40 kg)  
(Used also with CK-2000 and CK-3000 Hone Heads.)



#### CK-3373A Spring Retainer

Holds the CK-3372 slide in position during stone insertion or removal.

Also used on the CK-4355A inserter.



#### CK-3570 Hard Guide Shoe

For long life in high production shops. Recommended for use if honing with diamonds.

Shipping Weight: .5 lb. (.22 kg) (Not recommended with 400 grit or finer stone sets.)



# SV-I0/20/400/2400/CV/CK Accessories & Supplies

## CK-3000 Standard Hone Head

Range: 3.000" to 5.000" I.D. (76 mm to 127 mm)

### Basic Parts

Diameter Range: 3.0"-5.0" (72,2-127,0 mm)

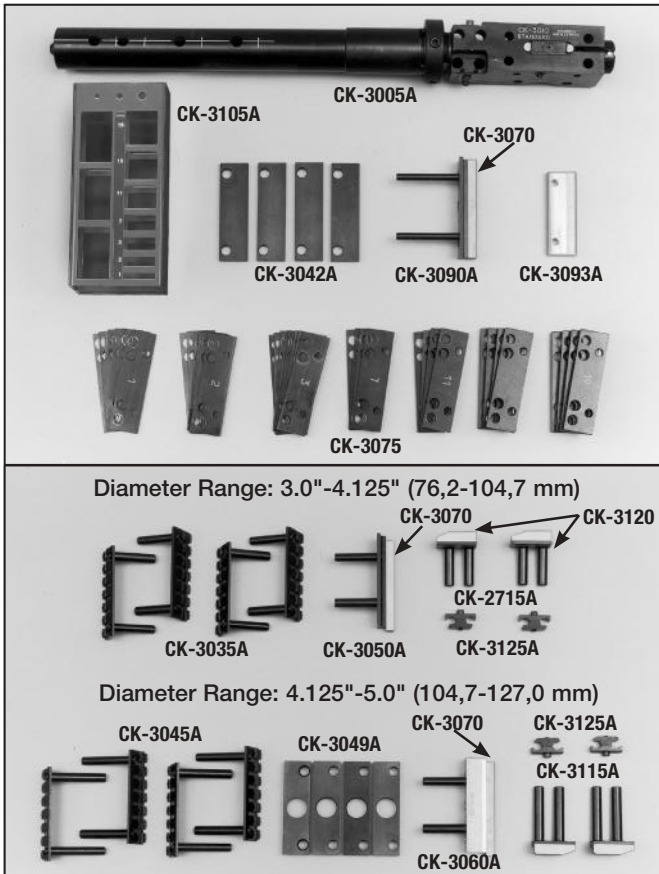

### CK-3000 Standard Hone Set

Part No.	Supplied with CK-3000	Description
CK-1823A	1	Tapered Locking Screw (Not shown)
CK-3005A	1	Standard Head and Tube Assembly
CK-3042A	4	Stone Shim, .25" (6,35 mm) (1 per package)
CK-3120	-	Alignment Guide Shoe and Screw Set (2 shoes per set) (Included in C-2715A and C-3115A)
CK-3125A	4	Clamp (1 per package)
CK-3105A	1	Shim Rack
CK-3090A	1	Centering Guide (Includes CK-3070)
CK-2635A	2 sets	Master Stoneholder Set (2 per set)
CK-2650A	1	Main Guide (Includes CK-3070)
CK-3070	-	1 Guide Shoe and 1 Screw Set (Included in CK-3050A, CK-3060, and CK-3090A)
CK-3093A	1	Centering Guide Shim (Used with CK-3090A)
CK-3075	1 set	Guide Shim Set
CK-3035A	2 sets	Master Stoneholder Set (2 per set)
CK-3050A	1	Main Guide (Includes CK-3070)
CK-2715A	1 set	Alignment Guide Set (2 per set) Range: 3.0"-3.75" (76,2-95,2 mm)
CK-3115A	1 set	Alignment Guide Set (2 per set) Range: 3.25"-5.0" (82,5-127,0 mm)
CK-3045A	2 sets	Master Stoneholder Set (2 per set)
CK-3049A	2 sets	Stone Shim Set .4375" (11,1 mm) (2 per set)
CK-3060A	1	Main Guide (Includes CK-3070)

### CK-3075 Shim Kit

(Included with CK-3000 Hone Head)



Kit Includes:

Part No.	Qty.	Description
CK-3071A	2 sets	Guide & Stone #1
CK-3072A	2 sets	Guide & Stone #2
CK-3073A	2 sets	Guide & Stone #3
CK-3074A	1 set	Guide & Stone #7
CK-3076A	1 set	Guide & Stone #11
CK-3077A	1 set	Guide & Stone #15
CK-3078A	1 set	Guide & Stone #19

(4 per set)

Applicable to CK-3000 and CK-2600 Hone Heads.

### Accessories

(Not included with CK-3000)

#### CK-3040A Standard Storage Rack

For orderly storage of Stoneholders and Alignment Guides.  
Shipping Weight: 3.5 lbs. (1,59 kg)  
(Used also with CK-2600 Hone Head.)



#### CK-3155A Setting Gage

Indicates shims required to set Guides and Stones to cylinder diameter. Also used to adjust Alignment Guides.  
Shipping Weight: .5 lbs. (.22 kg)  
(Used also with CK-2000 and CK-2600 Hone Heads.)



#### CK-3355A Stone Inserter

Changes Stones easily in seconds. Includes mounting bracket.  
Shipping Weight: 7.5 lbs. (3,40 kg)  
(Used also with CK-2000 and CK-2600 Hone Heads.)



#### CK-3373A Spring Retainer

Holds the CK-3372 slide in position during stone insertion or removal.  
Also used on the CK-4355A inserter.



#### CK-3570 Hard Guide Shoe

For long life in high production shops. Recommended for use if honing with diamonds.  
Shipping Weight: .5 lb. (.22 kg) (Not recommended with 400 grit or finer stone sets.)



# SV-10/20/400/2400/CV/CK Accessories & Supplies

## CK-4000 Large Hone Head

Range: 4.00" to 8.000" I.D. (102 mm to 203 mm)

### Basic Parts

Diameter Range: 4"-8" (101,6-203,2 mm)

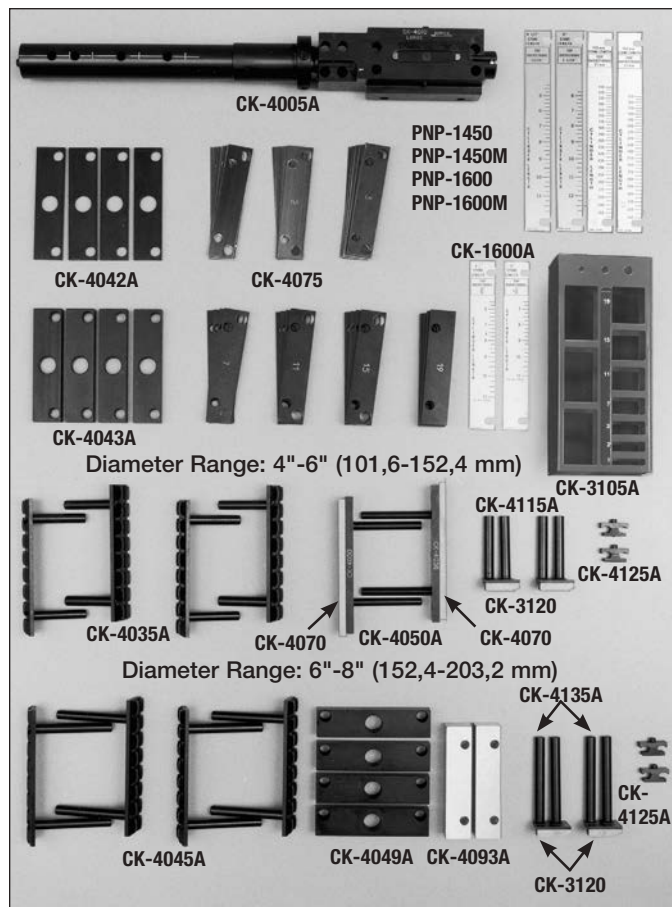

### CK-4000 Large Hone Set

Part No.	Supplied with CK-4000	Description
CK-1823A	1	Tapered Locking Screw (Not shown)
CK-4005A	1	Large Head and Tube Assembly
CK-4042A	4	Stone Shim, .25" (6,35 mm) (1 per package)
CK-4043A	4	Stone Shim, .5" (12,7 mm) (1 per package)
CK-3105A	1	Shim Rack
CK-4125A	4	Clamp (1 per package)
CK-1450A	1	Graduated Stroke Plate, for 4.5" (114,3 mm) stones (CK-10 Machines)
CK-1600A	1	Graduated Stroke Plate, for 6" (152,4 mm) stones (CK-10 Machines)
PNP-1450	1	Graduated Stroke Plate, metric version of PNP-1450 4.125" (114,3 mm)
PNP-1600	1	Graduated Stroke Plate, for 6" (152,4 mm) stones (CV-616 Machines)
PNP-1600M	1	Graduated Stroke Plate, metric version of PNP-1600
CK-4075	1 set	Guide Shim Set
CK-4035A	2 sets	Master Stoneholder Set (2 per set)
CK-4050A	2	Main and Centering Guide (Includes CK-4070)
CK-4070	-	1 Guide Shoe & 1 Screw Set (Included with CK-4050A)
CK-4115A	1 set	Alignment Guide Set (2 per set) (Includes CK-3120)
CK-3120	-	1 Guide Shoe and 1 Screw Set (2 per set) (Included with CK-4115A and CK-4135A)
CK-4045A	2 sets	Master Stoneholder Set (2 per set)
CK-4049A	2 sets	Stone Shim Set, .75" (19,0 mm) (2 per set)
CK-4093A	2	Main & Centering Guide Shims (1 per package)
CK-4135A	1 set	Alignment Guide Set (2 per set) (Includes CK-3120)

### CK-4075 Shim Kit

(Included with CK-4000 Hone Head)



Kit Includes:

Part No.	Qty.	Description
CK-4071A	2 sets	Guide & Stone #1
CK-4072A	2 sets	Guide & Stone #2
CK-4073A	2 sets	Guide & Stone #3
CK-4074A	1 set	Guide & Stone #7
CK-4076A	1 set	Guide & Stone #11
CK-4077A	1 set	Guide & Stone #15
CK-4078A	1 set	Guide & Stone #19

(4 per set)

### Accessories

(Not included with CK-4000)

#### CK-4155A Setting Gage

Indicates shims required to set Guides and Stones to cylinder diameter. Also used to adjust Alignment Guides.  
Shipping Weight: 3.5 lbs. (1,59 kg)



#### CK-4355A Stone Inserter

Changes stones easily in seconds. Includes mounting bracket.  
Shipping Weight: 9.5 lbs. (4,31 kg)



#### CK-3373A Spring Retainer

Holds the CK-4372 slide in position during stone insertion or removal. Also used on the CK-3355A inserter.



#### CK-4570 Hard Guide Shoe

For long life in high production shops. Recommended for use if honing with diamonds. Shipping Weight: .5 lb. (.22 kg) (Not recommended with 400 grit or finer stone sets.)



# SV-I0/20/400/2400/CV/CK Accessories & Supplies

## Tooling for Resizing High-Silicon Aluminum Alloy Blocks

Porsche, Mercedes Benz, Honda, GM Vega 2300

High silicon aluminum die-cast blocks do not require a steel or cast iron liner in the cylinder bore. Pure particles of silicon, about .001" (0,03 mm) in diameter, are dispersed in the aluminum alloy. To achieve a proper surface finish, the cylinders should be prepared so piston and rings contact only silicon. Silicon is very hard, so there will be very little wear in the cylinder bore. The aluminum's function is merely to "hold" the silicon particles which actually form the wall.

Excessively scored or worn cylinders can be reconditioned to accept oversize pistons. A special "Conditioning" operation is needed to remove aluminum from and between the silicon particles so the wall will be a silicon wall.

Tooling required:

Part No.	Description
MB-30	Honing Oil
C30-F85	Felt Set
C30-J54	Stones
AN-30	Silicon Compound
AN-35	Storage Box
C30-J84	Stones
CK-3035A	Master Holder Set, Stones
CK-3130A	Master Holder Set, Felts
C30-C03-81	Polishing Stones

## CK-234A Gear Set

Replacement fiber planetary gear set for the CV-616 and CK-10 hand-wheel assembly.



## CK-448A Gearbox Oil

CK-448A is a sulphur-free gearbox lubricant used in the CV-616 and LBB-1810 transmission case. Quart (.95 liter). Note: Use of 90 wt. hypoid lubricant will cause premature gearbox wear and is not recommended.



## CK-1436A Cover and Glass

For CK/CV load meter. Shipping Weight: .5 lb. (.22 kg)



## CK-1442A Replacement Amber Lens

For Dwell Light.



## CK-1444A Replacement Bulb

For Motor On and Dwell Indicator Lights.



## CV-616 Replacement Belts

Part No.	Description
CK-252A	Timing Belt
CK-192A	Flat Belt
CK-209A	"V" Belt, Upper
CK-498	"V" Belt, Lower
CK-1267A	"V" Belt, Blower



## CV-1100 Fiber Mats

## FL6X Portable Tool Adapter for CV-616, CK-10 and CK-21

Recommended tool for honing outboard motors. Must be special ordered. Call Customer Service, Sunnen Products Co. For details.



Shipping Weight: 13 lbs. (5,91 kg)

## PF-244A Gasket for Canister Lid

## CV-1010 Mandrel Adapter for use on CV-616, CK-10 or CK-21



The CV-1010 adapts standard mandrels in applications where the standard hone heads do not apply. Minimum diameter .75" (19 mm). Mandrel not included.

Shipping Weight: 7.5 lbs. (3,41 kg)

## Stroke Scale Plates for CV-616 Cylinder King

Part No.	Stone Length
PNP-1275A	2.75" (69,8 mm)
PNP-1350	3.5" (88,9 mm)
PNP-1450	4.5" (114,3 mm)
PNP-1600	6" (152,4 mm)
CV-1285A	9" (228,6 mm) (not shown)



For metric, add "M" to the part number.

## CK-6200 Clamp Kit for CK-21 includes:

Item No.	Part Number	Qty.	Description	Item No.	Part Number	Qty.	Description
1	CH-585A	1	Clamp Bar Assembly (includes 1a, 1b)	7	CK-1206A	1	Plate and Block Assembly (Pkg. of 1 includes 8, 9, 10, 11)
1a	CH-585	1	Clamp Bar, Inside	8	CK-1206	1	Plate, Lower
1b	CH-590	1	Clamp Bar, Outside	9	CK-1207	1	Block
3	CK-1195A	2	Cross Bar Assembly	10	CK-1211	1	Clamp Plate, Top
3a	PHP-555	1	Pin, Groove	11	PHS-528	2	Screws, .375-16 x 2.5", Hex Hd. Cap
4	CK-1220A	4	Block, Riser	12	CK-1208A	2	Stud (Pkg. of 1 includes 13)
5	CK-1215A	1	Crank Assembly	13	PHN-107A	2	Locknut (Flexloc #31FK-918)
6	CK-1213A	2	Clamp Nut (Pkg. of 1)	17	CK-3275A	1	Hook Rule (Inch and Metric Scales)
5	CK-1215A	1	Crank Assembly	18	CK-1237	1	Bar

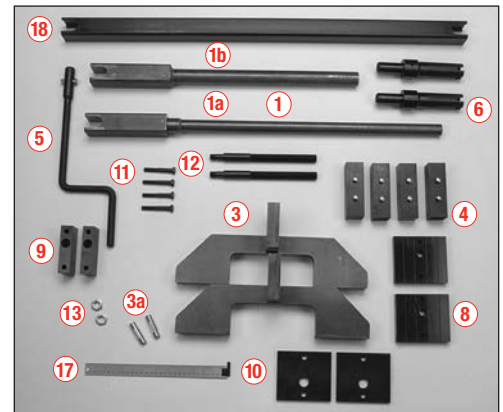

# SV-10/20/400/2400/CV/CK Accessories & Supplies

## Stone Sets for High Performance Engines Honed on Sunnen CV-616 and CK-10



These Stone Sets are available for producing specific finishes for high performance engines. Contact Customer Service, Sunnen Products Co. for full details. As a general rule, however, on standard cast iron blocks the following surface finish will be produced:

Stone Set	Approx. Surface Finish	
	Microinches $R_a$	Micrometers $R_a$
<b>EHU-412</b>	47-52	1,1-1,3
<b>EHN-512</b>	40-48	1,0-1,2
<b>JHU-525</b>	30-36	,75-,91
<b>JHU-623</b>	20-25	,50-,63
<b>JHU-818</b>	7-14	,18-,35
<b>C30-C03-81</b>	3-5	,07-,12

The surface finishes listed above were produced by honing a late model 350 cid Chevy small block. Finishes may vary due to variations in cast iron alloys, feed rates and honing oil used.

*NOTE: Some stones can be used for different diameter ranges, depending upon which Master Holder Set is used. Once a stone is inserted into the master holder, it must not be removed until replacement is necessary.*

Other abrasives are available for special applications. Call Customer Service, Sunnen Products Co. for information.

## AN-980 Chamfering Cone



Chamfers the sharp edges of cylinders for safe piston and ring installation. Handles all diameter cylinders or sleeves. Unit consists of tapered neoprene cone covered by long-lasting replaceable abrasive cone (plus a spare). Easy to use with .25" (6,3 mm) or larger drill.

Part No.	Description
<b>AN-980</b>	Replacement Parts
<b>AN-991A</b>	Extension
<b>AN-994A</b>	Replacement Cones (Pkg. of 6)

## How to Read Grit Size

The first numeral in the stone code designates the grit size. As shown in the examples below, the "1" in EEU-129 designates that the grit size is 70, as the "8" in JHU-820 designates a 400-grit stone.

Part No.	Description
<b>100 Series</b>	(example: EEU-129) - 70 grit
<b>200 Series</b>	(example: JUA-222) - 80 grit
<b>400 Series</b>	(example: EHU-412) - 150 grit
<b>500 Series</b>	(example: EHU-525) - 220 grit
<b>600 Series</b>	(example: JHU-625) - 280 grit
<b>800 Series</b>	(example: JHU-820) - 400 grit
<b>CO Series</b>	(example: C30-C03-81) - 600 grit

Most Common Hardness	
Automotive Suffix	Industrial Suffix
<b>10/14/18/20</b>	-5
<b>22/25</b>	-6
<b>35</b>	-7

## Sunnen Cylinder Reconditioning-Diamond Tooling CV or CK Applications

The following parts are required for use with Sunnen Diamond Stones using the CV-616 or CK-10 with the hone heads listed as follows:

### Standard Hone Head

Part No.	Description
<b>CK-3000</b>	Hone Head-Range 3.000" to 5.000" (76,2-127,0 mm)
<b>CK-3030A</b>	Stone Holder Set-Range 3.300" to 4.625" (83-117,5 mm)
<b>CK-3570†</b>	Hard Guide Shoe
<b>PNP-1275A</b>	Standard Stroke Scale Plate
<b>CK30-DM100</b>	Stone Set-Roughing

### Junior Hone Head

Part No.	Description
<b>CK-2600</b>	Hone Head-Range 2.600" to 3.500" (66,0-88,9 mm)
<b>CK-3030A*</b>	Stone Holder Set-Range 3.000" to 4.300" (76,2-109,2 mm)
<b>CK-3570†</b>	Hard Guide Shoe
<b>PNP-1275A</b>	Standard Stroke Scale Plate
<b>CK30-DM100</b>	Stone Set-Roughing

*\*NOTE: One-eighth inch will have to be ground off of each pin, and customer must make this alteration to meet the range.*

*Special Instructions: The CK-3030A ranges as shown for each hone head are what control the diameter range in which the diamond stones, using this tooling, can be used.*

*Order CK-1860A Thrust Bearing for SuperAbrasive Honing. The Standard Bearing will fail prematurely under these loads.*

*Use a Feed Rate which doesn't peg the Load Meter.*

*For Metal Bond Super Abrasive use in the Large Hone Head, call Customer Service, Sunnen Products Co.*

*Use of hardened guide shoes is recommended when using diamond stone sets.*

*† CK-3570 must be mounted on the CK-3050A Main Guide Holder*

*NOTE: For Diamond Abrasives for Rottler and K-Line hone heads see pg. 81.*

## PHT Plateau Honing Tool



CV/CK Hone Head	For Diameter Range		Abrasive Sets (320 GRIT)
	Inches	mm	
Midget	2.00-2.40	50,8-60,9	<b>C20-PHT-732</b>
	2.30-2.90	58,4-73,7	<b>C24-PHT-732</b>
Junior	2.90-3.40	73,7-86,4	<b>C30-PHT-731</b>
Standard	3.10-5.00	78,7-127,0	<b>C30-PHT-731</b>
Large	4.00-6.00	101,6-152,4	<b>C40-PHT-731</b>
	6.00-8.00	152,4-203,2	<b>C40-PHT-731</b>

## CK-3030A Diamond Stone Master Holder Set

*Note: Diamond stone master holders are available for the CK-2000 and CK-4000 hone heads. Write for bulletin #P-3404 and P-3405 or call Customer Service, Sunnen Products Co. for information.*



# SV-10/20/400/2400/CV/CK Accessories & Supplies

## Honing Stone Sets for Use With SV-10/SV-20/SV-400/SV-2400/CV/CK

	For Diameter Range		Used with Master Holder Set	Order These Stone Sets		Stone Length		Applications
	inches	mm		Roughing	Finishing	inches	mm	
Midget Hone Head 6 sets per box	2.0-2.7	50,8-68,6	<b>CK-2035A</b>	EEU-129	EEU-522	2.75	60,8	Hard Blocks
	2.0-2.7	50,8-68,6	<b>CK-2035A</b>	EEU-141	EEU-531	2.75	60,8	Standard Type Blocks
	2.0-2.7	50,8-68,6	<b>CK-2035A</b>	EEU-141	C20-J65-91	2.75	60,8	Alum. Cylinders (Special Finish Stones)
	2.4-2.7	60,9-68,6	<b>CK-2035A</b>	EAU-129	EAU-522	2.75	60,8	Hard Blocks
	2.4-3.0	60,9-76,2	<b>CK-2035A</b>	-	C24-A45	3	76,2	Base Finishing before Plateau Honing
	2.4-2.7	60,9-68,6	<b>CK-2035A</b>	EAU-141	EAU-531	2.75	60,8	Standard Type Blocks
	2.4-2.7	60,9-68,6	<b>CK-2035A</b>	EAU-141	C24-J65-91	2.75	60,8	Alum. Cylinders (Special Finish Stones)
	2.4-3.0	60,9-76,2	<b>CK-2035A</b>	-	C24-A45	3	76,2	Base Finishing before Plateau Honing
	2.7-3.0	68,6-76,2	<b>CK-2045A</b>	EAU-129	EAU-522	2.75	60,8	Hard Blocks
	2.7-3.0	68,6-76,2	<b>CK-2045A</b>	EAU-141	EAU-531	2.75	60,8	Standard Type Blocks
Junior Hone Head 6 sets per box	2.6-3.5	66,0-88,9	<b>CK-2635A</b>	EMN-123	EMN-525	3.5	88,9	Cylinders with Ports
	2.6-3.5	66,0-88,9	<b>CK-2635A</b>	EMU-123	EMU-518	2.75	60,8	Hard Blocks and Sleeves
	2.6-3.5	66,0-88,9	<b>CK-2635A</b>	EMU-133	EMU-525	2.75	60,8	Standard Type Blocks
	2.75-3.5	69,8-88,9	<b>CK-2635A</b>	-	EKN-525	3.5	88,9	Cylinders with Ports
	2.75-3.5	69,8-88,9	<b>CK-2635A</b>	-	EKN-512	3.5	88,9	Special Applications
	3.0-3.5	76,2-88,9	<b>CK-2635A</b>	-	EHU-412	2.75	60,8	Base Finishing before Plateau Honing
	3.0-3.5	76,2-88,9	<b>CK-2635A</b>	EHN-116	EHN-512	3.5	88,9	VW, Mercedes, High Nickel Race Blocks
	3.0-3.5	76,2-88,9	<b>CK-2635A</b>	EHN-123	EHN-518	3.5	88,9	Air Cooled Cylinders
	3.0-3.5	76,2-88,9	<b>CK-2635A</b>	EHN-133	EHN-525	3.5	88,9	Special Applications
	3.0-4.125	76,2-104,8	<b>CK-3035A</b>	EKU-133	EKU-525	2.75	60,8	Standard Type Blocks
Standard Hone Head 6 sets per box	3.25-4.125	82,5-104,8	<b>CK-3035A</b>	-	AHU-425	2.75	60,8	Aircraft Type Cylinders
	3.25-4.125	82,5-104,8	<b>CK-3035A</b>	-	AHU-425-01A	2.75	60,8	Aircraft Type (Hard Tip)
	3.25-4.125	82,5-104,8	<b>CK-3035A</b>	EHN-123	EHN-518	3.5	88,9	Air Cooled Cylinders
	3.25-4.125	82,5-104,8	<b>CK-3035A</b>	EHU-123	EHU-518	2.75	60,8	Hard Blocks and Sleeves
	3.25-4.125	82,5-104,8	<b>CK-3035A</b>	EHN-116	EHN-512	3.5	60,8	Hard Blocks and Sleeves
	3.25-4.125	82,5-104,8	<b>CK-3035A</b>	-	EHU-412	2.75	60,8	Base Finishing before Plateau Honing
	3.25-4.125	82,5-104,8	<b>CK-3035A</b>	EHU-133	EHU-525	2.75	60,8	Standard Type Blocks
	3.25-4.125	82,5-104,8	<b>CK-3035A</b>	-	JHU-525	2.75	60,8	Aluminum Blocks, Alum. Cylinders
	3.25-4.125	82,5-104,8	<b>CK-3035A</b>	-	JHU-623	2.75	60,8	High Nickel Race Blocks, Alum. Cylinders
	3.25-4.125	82,5-104,8	<b>CK-3035A</b>	-	JHU-625	2.75	60,8	Alum. Cylinders (Special Finish Stones)
	3.25-4.125	82,5-104,8	<b>CK-3035A</b>	-	JHU-818	2.75	60,8	High Nickel Race Blocks, Alum. Cylinders
	3.25-4.125	82,5-104,8	<b>CK-3035A</b>	-	JHU-820	2.75	60,8	Alum. Cylinders (Special Finish Stones)
	3.25-4.125	82,5-104,8	<b>CK-3035A</b>	-	C30-C03-81	2.75	60,8	Polishing, Plateau Honing
	4.125-5.0	104,8-127,0	<b>CK-3045A</b>	-	AHU-425	2.75	60,8	Aircraft Type Cylinders
	4.125-5.0	104,8-127,0	<b>CK-3045A</b>	EHN-123	EHN-518	3.5	88,9	Air Cooled Cylinders
	4.125-5.0	104,8-127,0	<b>CK-3045A</b>	EHU-123	EHU-518	2.75	60,8	Hard Blocks and Sleeves
	4.125-5.0	104,8-127,0	<b>CK-3045A</b>	EHN-116	EHN-512	3.5	60,8	Hard Blocks and Sleeves
	4.125-5.0	104,8-127,0	<b>CK-3045A</b>	-	EHU-412	2.75	60,8	Base Finishing before Plateau Honing
	4.125-5.0	104,8-127,0	<b>CK-3045A</b>	EHU-133	EHU-525	2.75	60,8	Standard Type Blocks
	4.125-5.0	104,8-127,0	<b>CK-3045A</b>	-	JHU-525	2.75	60,8	Aluminum Blocks, Alum. Cylinders
4.125-5.0	104,8-127,0	<b>CK-3045A</b>	-	JHU-623	2.75	60,8	High Nickel Race Blocks, Alum. Cylinders	
4.125-5.0	104,8-127,0	<b>CK-3045A</b>	-	JHU-625	2.75	60,8	Alum. Cylinders (Special Finish Stones)	
4.125-5.0	104,8-127,0	<b>CK-3045A</b>	-	JHU-818	2.75	60,8	High Nickel Race Blocks, Alum. Cylinders	
4.125-5.0	104,8-127,0	<b>CK-3045A</b>	-	JHU-820	2.75	60,8	Alum. Cylinders (Special Finish Stones)	
4.125-5.0	104,8-127,0	<b>CK-3045A</b>	-	C30-C03-81	2.75	60,8	Polishing, Plateau Honing	
Large Hone Head 1 set per box	4.0-6.0	101,6-152,4	<b>CK-4035A</b>	JUA-222	JUA-520	6	152,4	Hard Cylinders with Ports
	4.0-6.0	101,6-152,4	<b>CK-4035A</b>	JUG-222	JUG-520	4.5	114,3	Hard Cylinders
	4.0-6.0	101,6-152,4	<b>CK-4035A</b>	EUA-107	EUA-510	6	152,4	Cylinders with Ports
	4.0-6.0	101,6-152,4	<b>CK-4035A</b>	-	C40-A45	6	152,4	Base Finishing before Plateau Honing
	4.0-6.0	101,6-152,4	<b>CK-4035A</b>	EUG-113	EUG-514	4.5	114,3	Standard Type Blocks
	6.0-8.0	152,4-203,2	<b>CK-4045A</b>	EUA-107	EUA-510	6	152,4	Cylinders with Ports
	6.0-8.0	152,4-203,2	<b>CK-4045A</b>	-	C40-A45	6	152,4	Base Finishing before Plateau Honing
	6.0-8.0	152,4-203,2	<b>CK-4045A</b>	EUG-113	EUG-514	4.5	114,3	Standard Type Blocks
	6.0-8.0	152,4-203,2	<b>CK-4045A</b>	JUA-222	JUA-520	6	152,4	Hard Cylinders with Ports
	6.0-8.0	152,4-203,2	<b>CK-4045A</b>	JUG-222	JUG-520	4.5	114,3	Hard Cylinders





## Tooling GHSS I480/I950

### GHSS-1480/1950 Hone Head Stone Sizes

Diameter Range: 1.50 - 2.51" (38,10 – 63,75 mm)

Hone Head	Diameter Range		Stone Size Prefix (6 Stones/Set)	Abrasive Grade Suffix ‡	
	mm	in		Diamond (D, G, R)	CBN (N)
GHSS-1480	38,10 - 40,39	1.50 - 1.59	GH258-1-	GMG55 GMG85	NMG37
	40,13 - 42,42	1.58 - 1.67	GH258-2-		
	42,16 - 44,45	1.66 - 1.75	GH258-3-		
	44,20 - 46,23	1.74 - 1.82	GH258-4-		NMG85
	46,23 - 48,26	1.82 - 1.90	GH258-5-		
	48,26 - 50,29	1.90 - 1.98	GH258-6-		
GHSS-1950	50,04 - 55,88	1.97 - 2.20	GH258-3-	GMG55 GMG85	NMG05
	54,10 - 59,69	2.13 - 2.35	GH258-5-		
	58,17 - 63,75	2.29 - 2.51	GH258-7-		

### GHSS-1480/1950 Hone Head Brush Set Sizes

Diameter Range: 1.96 - 2.69" (37,85 - 68,33 mm)

Hone Head	Diameter Range		Brush Set Prefix (4 Brushes/Set)	Abrasive Grade Suffix
	mm	in		
GHSS-1480	37,85 - 44,45	1.49 - 1.75	GH258-1	PHT231 (80 Grit) PHT731 (320 Grit)
	39,88 - 46,48	1.57 - 1.83	GH258-2	
	41,91 - 48,51	1.65 - 1.91	GH258-3	
	43,94 - 50,55	1.73 - 1.99	GH258-4	
	45,97 - 52,58	1.81 - 2.07	GH258-5	
	48,01 - 54,61	1.89 - 2.15	GH258-6	
GHSS-1950	49,78 - 60,20	1.96 - 2.37	GH258-3	PHT231 (80 Grit) PHT731 (320 Grit)
	53,85 - 64,26	2.12 - 2.53	GH258-5	
	57,91 - 68,33	2.28 - 2.69	GH258-7	

‡ Other abrasive grades available - Contact Customer Service.

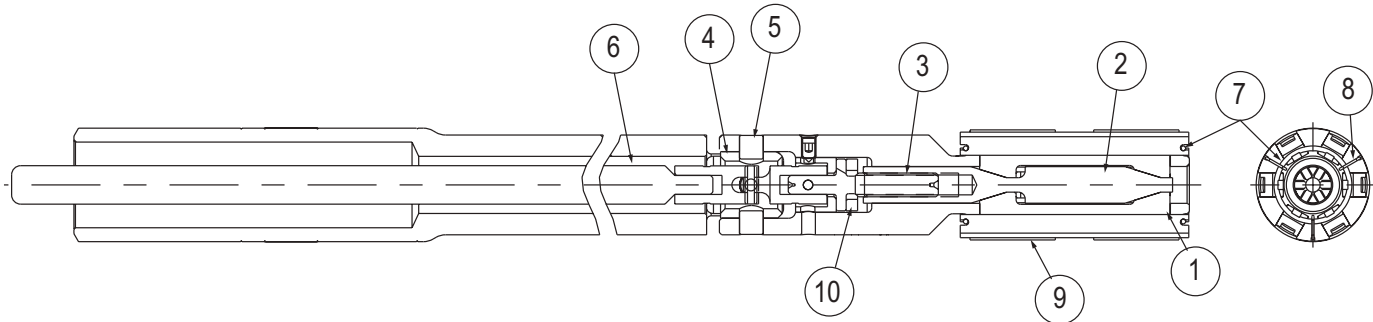

### Common Repair Parts - GHSS-1480/GHSS1950 (see X-GHSS-4402F for detailed repair parts)

Item No.	GHSS1480 Part No.	GHSS1950 Part No.	Qty	Description
1	G13B10616	B13B1066	1	Expander Plates (set of 6)
2	G12B354	G12B353	1	Expansion Cone
3	G17B405	G17G184	1	Expansion Screw
4	G15A175	G15A173	1	Universal Block
5	G16A210	G16A203	4	Universal Block Screw/Pin
6	G17C176	G17C177	1	Universal Joint & Rod
7	F40925	F40926	2	Retaining Spring for Stones
8	G24A127	G24A127	3	Spring Retainer
N/S	GH50	GH50	—	Spring Tool
9	—	—	6	Stone Assembly (See Charts Above)
N/S	—	F47538	1	Thrust Bearing
10	G20A189	F47537	1	Thrust Washer
N/S	GH80049	GH80049	—	Truing Grit (70 Grit)

N/S: Not Shown

# GHSS

## Tooling GHSS 2440/2800

### GHSS-2440/2800 Hone Head Stone Sizes

Diameter Range: 2.46 - 3.5" (62,48 – 88,90 mm)

Hone Head†	Diameter Range		Stoneholder (6 Holders)	MB Superabrasive Suffix ‡		
	mm	in		Diamond (D, G, R)	CBN (N)	
GHSS-2440(H)	62,48 – 64,26	2.46 – 2.53	G14C251-1-S6*	GH236GMG35E	GH236NMG65E	
	65,79 – 67,31	2.59 – 2.65	G14C251-2-S6*	GH236GMG55E		
	68,83 – 70,36	2.71 – 2.77	G14C233-1-S6*	GH236DMB55E		
GHSS-2800(H)	71,63 – 76,45	2.82 – 3.01	G14C233-1-S6*	GH236GMG75E	GH236NMG85E	
	75,44 – 80,01	2.97 – 3.15	G14C233-7-S6	GH236GMG75E		
	77,98 – 82,55	3.07 – 3.25	G14C233-4-S6*	GH236GMG85E	GH236NMG85E	
	80,52 – 85,09	3.17 – 3.35	G14C233-2-S6	GH236RMG95E		
	82,30 – 86,87	3.24 – 3.42	G14C233-8-S6	GH236RMG05E	GH236NMG05E	
	84,33 – 88,90	3.32 – 3.50	G14C233-3-S6*	GH236RMG005E		

### GHSS-2440/2800 Hone Head Brush Set Sizes

Diameter Range: 2.45 - 3.98" (62,23 - 101,09 mm)

Hone Head†	Diameter Range		Brush Set Prefix (4 Brushes/Set)	Abrasive Grade Suffix
	mm	in		
GHSS-2440(H)	65,02 - 75,95	2.56 - 2.99	GH251-1-	PHT331 (120 Grit)
	68,07 - 78,99	2.68 - 3.11	GH251-2-	
	71,37 - 82,30	2.81 - 3.24	GH233-1-	
GHSS-2800(H)	73,91 - 88,39	2.91 - 3.48	GH233-1-	PHT731 (320 Grit)
	80,26 - 94,74	3.16 - 3.73	GH233-4-	
	86,61 - 101,09	3.41 - 3.98	GH233-3-	

NOTES: † GHSS-2440/2800 are kits comprised of (1) hone head & (3) Stoneholder sets (marked "\*\*"). "H" suffix represents the hone head without stoneholder sets.  
‡ Other abrasive grades available - Contact Customer Service.

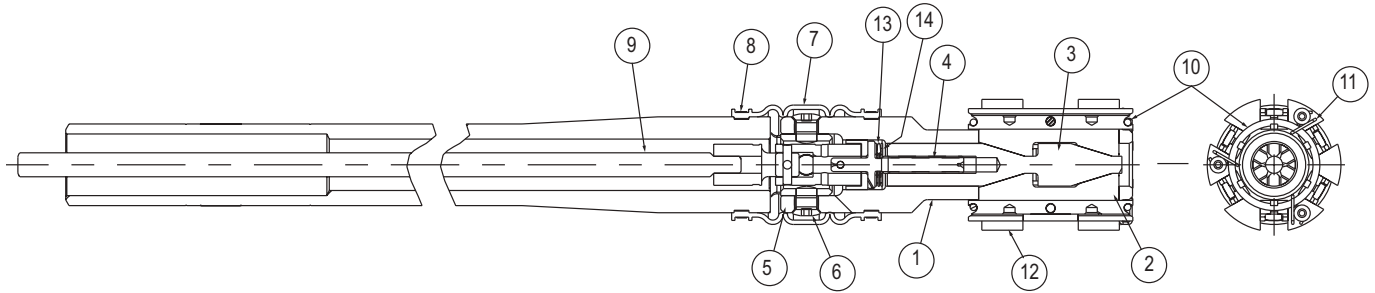

### Common Repair Parts - GHSS-2440/GHSS2800 (see X-GHSS-4402F for detailed repair parts)

Item No.	GHSS1480 Part No.	GHSS1950 Part No.	Qty	Description
1	G11C445	G11C444	1	Body
2	G13A2836	G13A2826	1	Expander Plates (set of 6)
3	G12B348	G12B347	1	Expansion Cone
4	G17G184	G17G184	1	Expansion Screw
5	G15A173	G15A171	1	Universal Block
6	G16A203	G16A202	4	Universal Screw/Pin
7	F43937	F43936	1	Universal Joint Boot
8	F5121GH2	F5121GH2	2	Universal Joint Boot Tie Strap
9	G17G185	G17G185	1	Universal Joint & Rod
10	F5043GH2	F5042GH2	2	Retaining Spring for Stones
11	G24A126	G24A126	3	Spring Retainer
N/S	GH50	GH50	—	Spring Tool
12			6	Stoneholder (See Charts Above)
13	F47538	F47538	1	Thrust Bearing
14	F47537	F47537	2	Thrust Washer
N/S	GH80049	GH80049	—	Truing Grit (70 Grit)

N/S: Not Shown

## Tooling GHSS 3410/4410/5410/6410

### GHSS-3410/4410/5410/6410 Hone Head

**Diameter Range:**  
3.43 – 7.42" (87,12– 188,47 mm)

#### Stone Sizes

Hone Head †	Diameter Range		Stoneholder (6 Holders)	MB Superabrasive Suffix ‡	
	mm	in		Diamond (D, G, R)	CBN (N)
GHSS-3410(H)	87,12 - 91,95	3.43 - 3.62	G14C233-7-S8*		
	89,92 - 94,49	3.54 - 3.72	G14C233-4-S8		
	93,98 - 98,55	3.70 - 3.88	G14C233-8-S8*	GH233GMG35E	
	96,27 - 100,84	3.79 - 3.97	G14C233-3-S8	GH233GMG47E	
	100,84 - 105,41	3.97 - 4.15	G14C233-9-S8*	GH233GMG55E	
	102,62 - 107,19	4.04 - 4.22	G14C233-6-S8		GH233NMG57E
GHSS-4410(H)	107,70 - 112,27	4.24 - 4.42	G14C233-10-S8*		GH233NMG65E
	112,52 - 117,09	4.43 - 4.61	G14C233-8-S8*	GH233GMG75E	
	114,81 - 119,38	4.52 - 4.70	G14C233-3-S8	GH233GMB75E	
	119,38 - 123,95	4.70 - 4.88	G14C233-9-S8*	GH233GMG85E	GH233NMG85E
	121,16 - 125,73	4.77 - 4.95	G14C233-6-S8	GH233GMB85E	
	126,24 - 130,81	4.97 - 5.15	G14C233-10-S8*	GH233RMG95E	
GHSS-5410(H)	129,79 - 134,11	5.11 - 5.28	G14C233-16-S8	GH233RMG05E	GH233NMG05E
	133,10 - 137,67	5.24 - 5.42	G14C233-11-S8*	GH233RMG005E	
	ranges are 25,4 mm (1.00 in) larger than the GHSS-4410 ranges				
GHSS-6410(H)	ranges are 50,8 mm (2.00 in) larger than the GHSS-4410 ranges				

### GHSS-3410/4410/5410/6410 Hone Head

**Diameter Range:**  
3.42 – 7.90" (86,87– 200,66 mm)

#### Brush Sets Sizes

Hone Head †	Diameter Range		Brush Set Prefix (4 Brushes/Set)	Abrasive Grade Suffix
	mm	in		
GHSS-3410(H)	86,87 - 100,33	3.42 - 3.95	GH233-1	PHT331 (120 Grit)
	89,92 - 104,39	3.54 - 4.11	GH233-7	
	96,27 - 110,74	3.79 - 4.36	GH233-8	
	102,62 - 117,09	4.04 - 4.61	GH233-9	
	109,22 - 123,70	4.30 - 4.87	GH233-10	
	117,09 - 131,32	4.61 - 5.17	GH233-11	
GHSS-4410(H)	112,27 - 125,22	4.42 - 4.93	GH233-4	PHT731 (320 Grit)
	114,81 - 129,29	4.52 - 4.89	GH233-8	
	121,16 - 135,64	4.77 - 5.09	GH233-9	
	127,76 - 142,24	5.03 - 5.60	GH233-10	
	135,64 - 149,86	5.34 - 5.90	GH233-11	
	GHSS-5410(H)   ranges are 25,4 mm (1.00 in) larger than the GHSS-4410 ranges			
GHSS-6410(H)   ranges are 50,8 mm (2.00 in) larger than the GHSS-4410 ranges				

NOTES: † GHSS-3410/4410/5410/6410 are kits comprised of (1) hone head & (4) Stoneholder sets (marked "\*\*"). "H" suffix represents the hone head without stoneholder sets.

‡ Other abrasive grades available - Contact Customer Service.

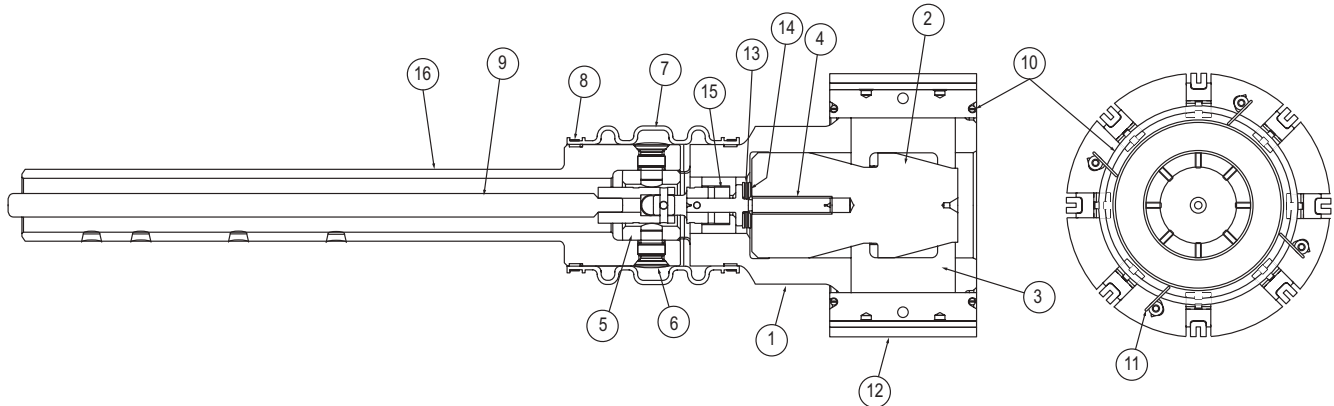

### Common Repair Parts - GHSS-3410/4410/5410/6410 (see X-GHSS-4402F for detailed repair parts)

Item No.	GHSS3410 Part No.	GHSS4410 Part No.	GHSS5410 Part No.	GHSS6410 Part No.	Qty	Description
1	G11C459	G11D320	G11G575	G11G626	1	Body
2	G13A2898	G13A2918	G13A2918	G13A2918	1	Expander Plates (set of 8)
3	G12B337	G12B337	G12G380	G12G412	1	Expansion Cone
4	G17B341	G17B341	G17B341	G17B341	1	Expansion Screw
5	G15A167	G15A167	G15A167	G15A167	1	Universal Block
6	G16A182	G16A182	G16A182	G16A182	4	Universal Block Screw/Pin
7	F43927	F43927	F43927	F43927	1	Universal Joint Boot
8	F5121GH2	F5121GH2	F5121GH2	F5121GH2	2	Universal Joint Boot Tie Strap
9	G17C159	G17C159	G17C159	G17C159	1	Universal Joint & Rod
10	F5041GH2	F5045GH2	F2075	F2075	2	Retaining Spring For Stones
11	G24A125	G24A125	G24A125	G24A125	8	Spring Retainer
N/S	GH50	GH50	GH50	GH50	—	Spring Tool
12					6	Stoneholder (See Charts Above)
13	F47530	F47530	F47530	F47530	1	Thrust Bearing
14	F47531	F47531	F47531	F47531	2	Thrust Washer
15	G20A177	G20A177	G20A177		1	Spacer
16	G18C222	G18C222	G18C222	G18C222	1	Driveshaft
N/S	GH80049	GH80049	GH80049	GH80049	—	Truing Grit (70 Grit)

N/S: Not Shown

# GHTS

## Tooling GHTS 2400/2800

### GHTS-2440/2800 Hone Head

Diameter Range:  
2.39 – 3.64" (60,71 – 92,46 mm)

#### Stone Sets

Hone Head	Diameter Range		Size Prefix	Set Qty. (4 or 6)		Abrasive Suffix †	
	mm	in		Diamond (D, G, R)	CBN (N)		
GHTS-2440	60,71 - 65,28	2.39 - 2.57	GT62-	4	6	GMG35	NMG57
	64,26 - 69,34	2.53 - 2.73	GT71-	4	6	GMG55	
	69,09 - 74,17	2.72 - 2.92	GT76-	4	6	GMG57	
	73,91 - 78,74	2.91 - 3.10	GT81-	4	6	GMG75	
	78,74 - 83,57	3.10 - 3.29	GT86-	4	6	GMG85	
GHTS-2800	71,37 - 78,23	2.81 - 3.08	GT71-	4	6	RMG05	NMG05
	75,44 - 82,80	2.97 - 3.26	GT76-	4	6		
	80,26 - 87,63	3.16 - 3.45	GT81-	4	6		
	85,09 - 92,46	3.35 - 3.64	GT86-	4	6		

### GHTS-2440/2800 Hone Head

Diameter Range:  
2.41 – 3.94" (61,21 – 100,08 mm)

#### Brush Sets Size†

Hone Head	Diameter Range		Size Prefix	Set Qty. (4 or 6)		Abrasive Suffix
	mm	in				
GHTS-2440	61,21 - 73,15	2.41 - 2.88	GT62-	4	6	PHT331 (120 Grit)
	65,02 - 76,71	2.56 - 3.02	GT71-	4	6	
	69,85 - 81,53	2.75 - 3.21	GT76-	4	6	
	74,68 - 86,36	2.94 - 3.40	GT81-	4	6	
	79,50 - 91,19	3.13 - 3.59	GT86-	4	6	
GHTS-2800	71,37 - 85,60	2.81 - 3.37	GT71-	4	6	PHT731 (320 Grit)
	76,20 - 90,42	3.00 - 3.56	GT76-	4	6	
	81,03 - 95,25	3.19 - 3.75	GT81-	4	6	
	85,85 - 100,08	3.38 - 3.94	GT86-	4	6	

NOTES: † Abrasive Stone Set Part Numbers are a Size Prefix + Set Qty. + Abrasive Suffix, e.g., GT62-6-GMG85 or GT71-4-PHT731.

‡ Other abrasive grades available - Contact Customer Service.

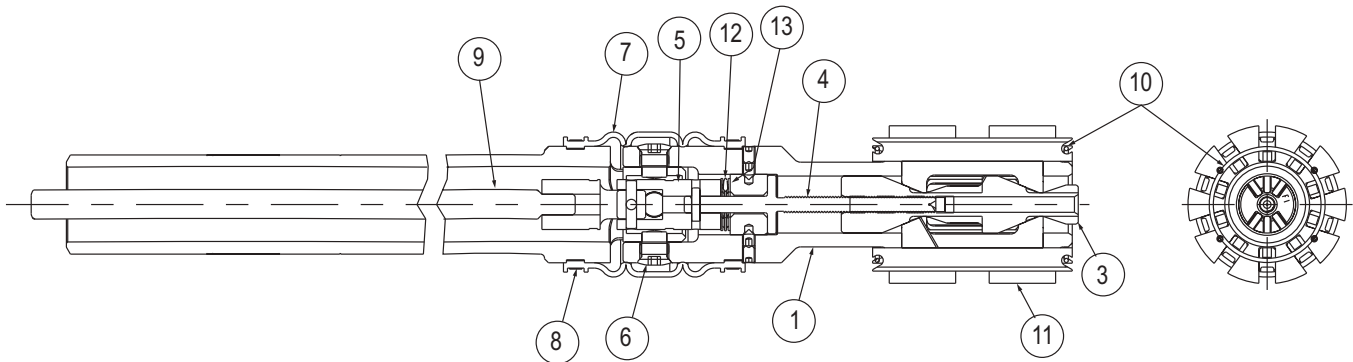

### Common Repair Parts - GHTS-2440 / GHTS2800

Item No.	GHTS2440 Part No.	GHTS2800 Part No.	Qty	Description
1	G11C553	G11C499	1	Body
2	G13A333[ ]	G13A308[ ]	1	Expander Plates ([ ] = set qty of 4, 6, or 10)
3	G12C241	G12C232	1	Expansion Cone
4	G17B500	G17B436	1	Expansion Screw
5	G15A173	G15A171	1	Universal Block
6	G16A203	G16A202	4	Universal Block Screw/Pin
7	F43937	F43936	1	Universal Joint Boot
8	F5121GH2	F5121GH2	2	Universal Joint Boot Tie Strap
9	G17C212	G17C168	1	Universal Joint & Rod
10	F5127	F5127	2	Retaining Spring for Stones
N/S	GH50	GH50	—	Spring Tool
11	- - -	- - -	4 or 6	Stone Assembly (See Charts Above)
12	F47538	F47538	1	Thrust Bearing
13	F47537	F47537	2	Thrust Washer
N/S	GH80049	GH80049	—	Truing Grit (70 Grit)

N/S: Not Shown

## Tooling – GHTS 3410/4410/5410

### GHTS-3410/4410/5410 Hone Head

**Diameter Range:**  
3.42 – 5.53" (86,87 – 140,46 mm)

#### Stone Sets†

Hone Head	Diameter Range		Size Prefix	Set Qty. (6)	Abrasive Suffix ‡	
	mm	in			Diamond (D, G, R)	CBN (N)
GHTS-3410	86,87 - 93,47	3.42 - 3.68	GH261-1-	6	GMG37	NMG57
	92,96 - 100,08	3.66 - 3.94	GH261-2-	6		
	99,57 - 106,68	3.92 - 4.20	GH261-3-	6		
	106,17 - 113,28	4.18 - 4.46	GH261-4-	6		
GHTS-4410	112,27 - 118,87	4.42 - 4.68	GH261-1-	6	GMG85	NMG05
	118,36 - 125,48	4.66 - 4.94	GH261-2-	6		
	124,97 - 132,08	4.92 - 5.20	GH261-3-	6		
	131,57 - 138,68	5.18 - 5.46	GH261-4-	6		
GHTS-5410	ranges are 25,4 mm (1.00 in) larger than the GHTS-4410 ranges					

### GHTS-3410/4410/5410 Hone Head

**Diameter Range:**  
3.43 – 5.69" (87,12 – 144,53 mm)

#### Brush Sets Sizes†

Hone Head	Diameter Range		Size Prefix	Set Qty. (6)	Abrasive Suffix	
	mm	in			120 Grit	320 Grit
GHTS-3410	87,12 - 101,35	3.43 - 3.99	GH261-1-	6	PHT331 (120 Grit)	
	93,98 - 108,20	3.70 - 4.26	GH261-2-	6		
	100,84 - 115,06	3.97 - 4.53	GH261-3-	6		
	107,70 - 121,92	4.24 - 4.80	GH261-4-	6		
GHTS-4410	112,52 - 126,75	4.43 - 4.99	GH261-1-	6	PHT731 (320 Grit)	
	119,38 - 133,60	4.70 - 5.26	GH261-2-	6		
	126,24 - 140,46	4.97 - 5.53	GH261-3-	6		
	133,10 - 147,32	5.24 - 5.80	GH261-4-	6		
GHTS-5410	ranges are 25,4 mm (1.00 in) larger than the GHTS-4410 ranges					

NOTES: † Abrasive Stone Set Part Numbers are a Size Prefix + Set Qty. + Abrasive Suffix, e.g., GH261-4-GMG85 or GH261-4-PHT731.

‡ Other abrasive grades available - Contact Customer Service.

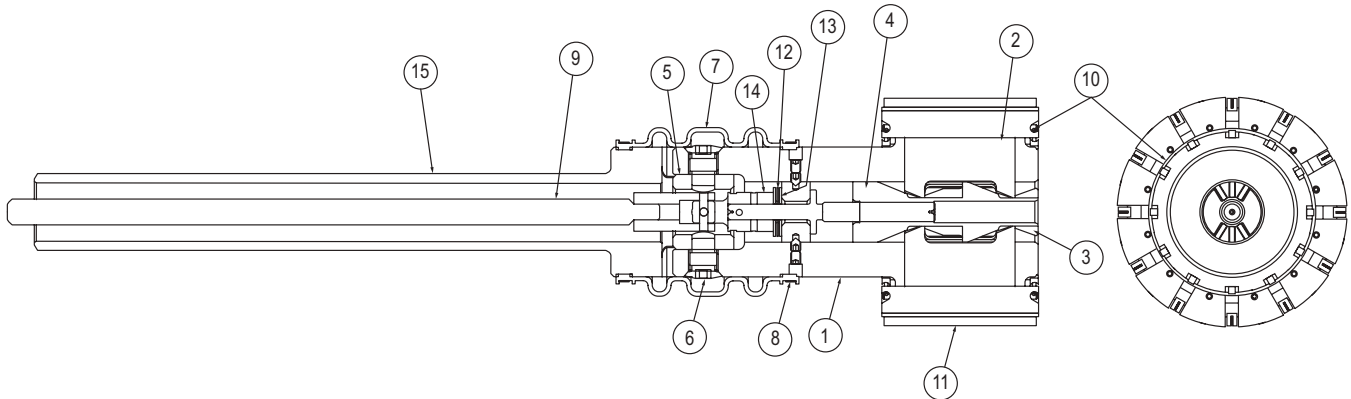

### Common Repair Parts - GHTS-3410/4410/5410

Item No.	GHTS3410 Part No.	GHTS4410 Part No.	GHTS5410 Part No.	Qty	Description
1	G11C475	G11D361	G11G556	1	Body
2	G13A30212	G13A31312	G13A31312	1	Expander Plates (set of 12)
3	G12C233	G12C233	G12G373	1	Expansion Cone
4	G17B411	G17B411	G17B411	1	Expansion Screw
5	G15A167	G15A167	G15A167	1	Universal Block
6	G16A182	G16A182	G16A182	4	Universal Screw/Pin
7	F43927	F43927	F43927	1	Universal Joint Boot
8	F5121GH2	F5121GH2	F5121GH2	2	Universal Joint Boot Tie Strap
9	G17C159	G17C159	G17C159	1	Universal Joint & Rod
10	F5049GH2	F50410	F2075	2	Retaining Spring For Stones
N/S	GH50	GH50	GH50	—	Spring Tool
11	---	---	---	6	Stone Assembly (See Charts Above)
12	F47530	F47530	F47530	1	Thrust Bearing
13	F47531	F47531	F47531	2	Thrust Washer
14	G20A177	G20A177	G20A177	1	Spacer
15	G18C222	G18C222	G18C222	1	Drive Shank
N/S	GH80049	GH80049	GH80049	—	Truing Grit (70 Grit)

N/S: Not Shown

# Specialized SV-10/SV-20/CV/CK Tooling

## Tooling Required for Honing Nikasil Cylinders with CK/CV Tooling

Diameter Range - 3.300-4.625 (83-117,5 mm)

### CK-3030A Diamond Stone Master Holder Set



### Roughing Stones

HP28DM95 (2 Required)

### Finishing Stones

HP28DM05 (2 Required)

*Note: Use Sunnen standard CK-3070 Bronze Guide Shoes when honing Nikasil Cylinders.*

For deglazing Nikasil Cylinders, use Sunnen Stone EHU-412 or C30-A43.

## Tooling Required for Honing Dart Blocks

CK/CV Type Machines	Portable Tooling
C30-A25	N37-A25
C30-A55	N37-A55
C30-J65	N37-J65
C30-J85	MM33-J85
CK-3570 Hard Guide Shoe*	
CK-3070-NY3X Delron Guide Shoe	

*\*Noted as Titanium Guide Shoe in Dart Literature. Recommendation from Dart Machinery.*

## Sunnen Diamond Abrasives for Rottler Hone Head

Part No.	Description
D37201-P640-4	Set of 4, 320 grit (GMG75)
D38201-P640-4	Set of 4, 400 grit (GMG85)

## Sunnen Diamond Abrasives for K-Line Hone Head

Part No.	Description
D37201-N671-6	Set of 6, 320 grit (GMG75)
D38201-N671-6	Set of 6, 400 grit (GMG85)
D60021-N671-6	Set of 6, 500 grit (GMB95)

*For more information ask for Bulletin P-2802*

## Sunnen Super Abrasive Honing on CV-616

Part No.	Description
CV616-HN2X	.5 Rate Feed Panels

# CH-100 Line Honing Machine

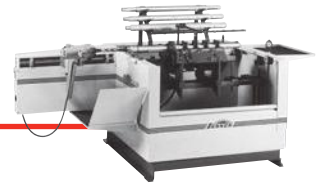

## Accessories and Supplies for CH-100, CHV-31, CH-20 and Ch-40



### Complete Hone Units

Hone Unit	Approx. Ship. Weight		Diameter Range		Stone Length	Comments	
	lbs.	kg	inches	mm			
8RY-2400G	27.5	12,5	2.400-2.700	61-69	27"	Hone Unit includes 1 set of 8 stones and 16 shoes	
8RY-2700G	31.2	14,2	2.700-3.000	69-77	27"		
10RY-1800F	34	15,4	1.800-2.100	46-54	24.375"		
10RY-2100F	45	20,4	2.100-2.400	54-61	24.375"		
10RY-2400G	40	18,1	2.400-2.700	61-69	33.750"		
10RY-2700G	45	20,4	2.700-3.000	69-77	33.750"		
10RY-3000H	50	22,6	3.000-3.500	77-89	33.750"		Hone Unit includes 1 set of 10 stones and 20 shoes
10RY-4500H	60	27,2	4.500-5.000	115-127	33.750"		
10RY-5000H	70.5	32,0	5.000-5.500	127-140	33.750"		
10RY-5500H	80.5	36,6	5.500-6.000	140-152	33.750"		
10RY-6000H	97.0	44,1	6.000-6.500	152-165	33.750"		
10RY-6500H	113.5	51,6	6.500-7.000	165-178	33.750"		
15RY-3500H	85	38,5	3.500-4.000	89-102	50.625"	Hone Unit includes 1 set of 15 stones and 30 shoes	
15RY-4000H	105	47,6	4.000-4.500	102-115	50.625"		
15RY-4500H	120	54,4	4.500-5.000	115-127	50.625"		
15RY-5000H	107.0	48,6	5.000-5.500	127-140	50.625"		
15RY-5500H	122.0	55,4	5.500-6.000	140-152	50.625"		
15RY-6000H	147.0	66,8	6.000-6.500	152-165	50.625"		
15RY-6500H	172.0	78,2	6.500-7.000	165-178	50.625"		

### Replacement Stones and Shoes

Stones (5 per box) Ship Wt. 1.25 lbs. (,57 kg) per box	Shoes (10 per box) Ship Wt. 2 lbs. (,9 kg) per box	Bronze Shoes for Prod. use
<b>RY24-J49</b>	RG-D	RG-B
<b>RY24-J49</b>	RG-D	RG-B
<b>RY18-J49</b>	RF-D	RF-B
<b>RY18-J49</b>	RF-D	RF-B
<b>RY24-J49</b>	RG-D	RG-B
<b>RY24-J49</b>	RG-D	RG-B
<b>RY24-J49</b>	RH-D	RH-B
<b>RY24-J49</b>	RH-D	RH-B
<b>RY24-J49</b>	RH-D	RH-B
<b>RY24-J49</b>	RH-D	RH-B
<b>RY24-J49</b>	RH-D	RH-B
<b>RY24-J49</b>	RH-D	RH-B
<b>RY24-J49</b>	RH-D	RH-B
<b>RY24-J49</b>	RH-D	RH-B
<b>RY24-J49</b>	RH-D	RH-B
<b>RY24-J49</b>	RH-D	RH-B
<b>RY24-J49</b>	RH-D	RH-B

Call Customer Service, Sunnen Products Co., for price and availability. Special mandrels available on request.

### CH-36 Storage Rack

Free-standing unit provides convenient storage for six Hone Units. Top tray holds wrenches, honing stones, etc. Rack bottom catches oil runoff from mandrels. Sturdy, heavy steel construction. (Hone Units must be ordered separately.)



### CH-46 Storage Rack



The CH-46 is a compact mandrel storage rack designed to conveniently mount over the drain pan of the CH-100 Horizontal Hone. It accommodates three 8 or 10 stone mandrels up to 3.0" (76,2 mm) diameter.

### Softer Stones for Line Honing Aluminum Blocks



Blocks manufactured of aluminum require an abrasive with a softer bond. Softer stones allow honing without the problem of "loading" often experienced when honing this soft material.

Application	Stone Number
10RY-1800F 10RY-2100F	RY18-J45
8RY-2400G thru 15RY-6500F	RY24-J45

Shipping Weight: 1.25 lbs.  
(,57 kg) per box

### CCG-100 Cap Checker

Checks the height of main bearing caps referenced from the parting line.



### Replacement Parts for CH-75A Hone Driver

Part No.	Description
<b>GGN-111A</b>	Feed screw with washer
<b>GGN-118C</b>	Feed link
<b>CH-76A</b>	Mandrel drive plate with set screws
<b>GGN-112A</b>	Stone release lever with screws

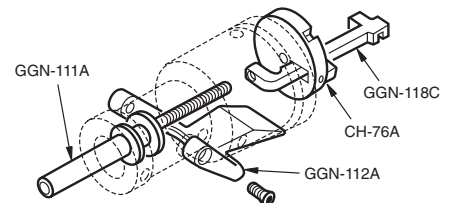

# CH-100 Accessories & Supplies

## Honing Unit Replacement Parts

Honing Unit	Centering Pins	"T" Hex Wrench	Adjustment Key
8RY-2400G	PHP-511	PWM-11A	LN-5785A All Mandrels
8RY-2700G	PHP-512	PWM-11A	
10RY-1800F	PHP-511	PWM-9A	
10RY-2100F	PHP-511	PWM-9A	
10RY-2400G	PHP-511		
10RY-2700G	PHP-512		
10RY-3000H	PHP-512		
10RY-4500H	RY-187		
15RY-3500H	RY-184		
15RY-4000H	RY-186		
15RY-4500H	RY-187		
10RY-5000H	RY-188	PWM-11A	
10RY-5500H	RY-189		
10RY-6000H	RY-190		
10RY-6500H	RY-192		
15RY-5000H	RY-188		
15RY-5500H	RY-189		
15RY-6000H	RY-190		
15RY-6500H	RY-192		

## Replacement Parts for CH Drill Motors

Drill Motor Part No.	Part Description	Part No.
CH-158	Brush Set	CH-158-1A
CH-168	Brush Set	CH-168-2A
CH-705	Brush Set	CH-726-A

## CH-455 Cradle Assembly

Shipping Weight: 256 lbs. (116,4 kg)

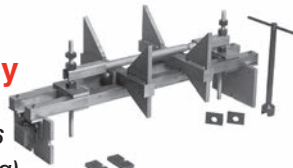

## CH-525 Oil Control Assembly

Shipping Weight: 12 lbs. (5,4 kg)



## CH-650 Hone Support

The CH-650 Hone Support is intended to be used with Sunnen CH-100 Horizontal Hone. It is designed to aid operator in loading and unloading of heavy hone units.



## CH-40 Horizontal Hone Driver Kit

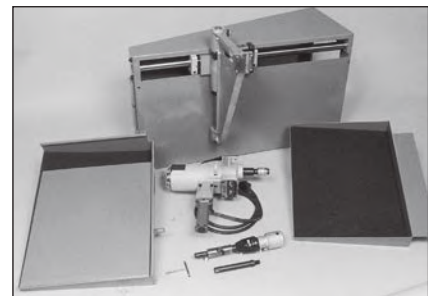

For the shop that is short on available floor space, line honing capability may be added to an existing CV-616 or CK-10 by ordering the CH-40 Horizontal Hone Driver Kit. Honing units, CH-455 Cradle Assembly, and CH-525 Oil Control Assembly must be ordered separately.

### Available Kits:

Part No.	Description
CH-40K	115v, 60 Hz (Pearl Gray)
CH-40A	220v, 50 Hz (Pearl Gray)

Shipping Weight: 280 lbs. (127,3 kg)

## CH-50 Conversion Kit

For customers who have their CV-616 or CK-10 set up for line honing we offer the CH-50 Conversion Kit to convert their line honing setup into a CH-100 line honing machine.

The CH-50 Conversion Kit includes everything needed to convert to a CH-100 except electricals. The customer will have to provide all switches and receptacles.

Available in Pearl Gray only. Contact Customer Service, Sunnen Products for pricing and delivery.

Note: The CH-455 Cradle will no longer be required and cannot be returned for credit.

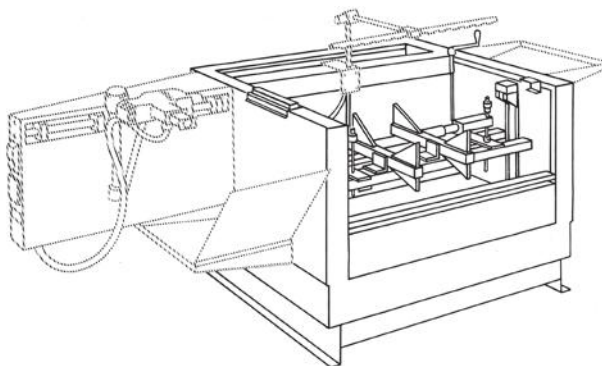

## Camshaft Bore Honing on Overhead Cam Cylinder Heads

For the small shop with limited requirements, mandrels may be special ordered to allow honing various O.H.C. cylinder heads. Call Customer Service, Sunnen Products Co. for details and information.

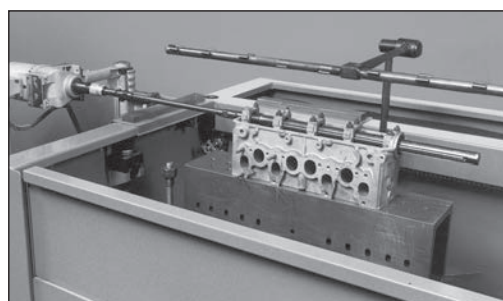

Cylinder head being honed on CH-100 Honing Machine with a hand fed Porta-Hone.

## OHC Line Hone Mandrel

Part No.	Description
7PL-1031M*	For VW Rabbit, Omni, Horizon, Ford 2.5 and 4.6 1.021"-1.094" (25,9-27,8 mm) Extended Range with .125" Shim-1.219" (31,0 mm)
7PL-1312M*	For Mitsubishi 3.0, Chrysler 2.2 and 2.5, Isuzu, Toyota 4 and 5 ME, Mazda GLC, Nissan Z24-Z28, Mitsubishi 2.6 1.292"-1.375" (32,8-34,9 mm) Extended Range with .125" Shim-1.500 (38,1 mm)
WB-D	Guide Shoes (2/box)
P28J27	Stones (12-Roughing)
P28J47	Stones (12-General Purpose)
P28J67	Stones (12-Finishing)

See Product Bulletin P-5501A thru P-5505A for more OHC Mandrel Selections.

\*Recommend using with GGN-150 Mandrel Driver and AN-87 Yoke adapter in CH-100 Line Hone Machine.



# CH-100 Accessories & Supplies

## PLB-100 Line Boring Attachment

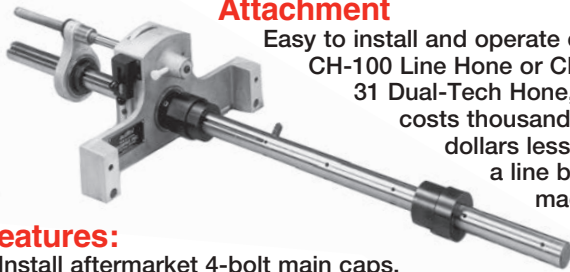

Easy to install and operate on CH-100 Line Hone or CHV-31 Dual-Tech Hone, and costs thousands of dollars less than a line boring machine.

### Features:

- Install aftermarket 4-bolt main caps.
- Bore semi-finished, mismatched and metallized caps and blocks and also diesel blocks.
- Cuts thrust faces with special cutter.
- 1.5" (38,1 mm) hard chrome bar with tool bit holes on 5" (127,0 mm) centers-length 48" (1220 mm).
- Boring range 1.800-5.250" (45,7-133,3 mm).
- Lightweight, 15 lbs. (6,8 kg) plus bar.

### Optional Centering Rings

For other engines. These optional rings are stepped to provide two sizes per ring. Example: The standard set PLB-235 will fit a small and big block Chevrolet.



Part No.	Description
PLB-2941/3192	2.9412"-2.9425", 3.1922"-3.1930" Fits Ford 351, 352, 427, 428, 351M, 351W, 400, 429.
PLB-240	2.4906"-2.4916", 2.8406"-2.8415" Fits 400 small block Chevrolet and small journal pre-1968 283, 327, 302 Chevrolet.
PLB-3438/3188	3.438"-3.439", 3.1880"-3.189" Fits Pontiac 350, 389, 400, 428, 455; Oldsmobile 350N, 400, 425, 455; Buick 400, 430, 455, 265, 301, 350, 400.
PLB-2692/2817	2.6925"-2.6935", 2.8175"-2.8185" Fits Chrysler, Plymouth 340, 318, 301, 273, 383.
PLB-3002/2942	3.0025"-3.003", 2.9425"-2.9435" Fits Chrysler, Plymouth 360, 170, 198, 225, 413, 426, 440.

Note: Sizes may be combined on special order. Call Customer Service, Sunnen Products Co.

## PLB-1200 Cam Boring Attachment 1.25" Boring Bar

Turn your present line hone into a cam boring machine for V6 and V8 blocks. The PLB-1200 allows you to install over-size bearings and roller bearings in performance blocks. Boring Range: 2.000 to 2.750 in. (50,8-69,85 mm)

Part No.	Description
PLB-1200A	Cam Boring Attachment (includes the following):
PLB-1400A	Cam Boring Stand
PLB-1300A	PLB-100 Mounting Adapter
PLB-1260A	Stud Drive Shaft
PLB-1235A	Adjustable Bushings (Pkg. Of 2)
PLB-1275A	Adjustable Tool Bit
PLB-1280A	Adj. Pilot Lock Tool
PLB-1290A	Adj. Pilot Lock Tool
PLB-1210	Boring Bar Assembly
PM-1733A	Micrometer (for setting tool bits)
<b>Tooling Required for 2.250" - 2.750" (57,15 - 69,88 mm)</b>	
PLB-2400A	Blade Set
PLB-1295	Tool Bit

## Ordering Information

	Part No.	Description
	PLB-100*	Line Boring Attachment
	PLB-500	Adjustable Centering Rings (set of two) includes blades for range from 2.400"-3.000" (60,9-76,2 mm)
	PLB-3000	Blade Set range: 3.000"-3.600" (76,2-91,4 mm)
	PLB-3600	3.600"-4.200" (91,4-106,6 mm)
	PLB-4200	4.200"-4.800" (106,6-121,9 mm)
	PLB-4800	4.800"-5.400" (121,9-137,2 mm)
	PLB-349	Carbide Tipped Cutter 1.800"-2.450" (45,7-62,2 mm)
	PLB-350*	Indexable Carbide Cutters with insert, screw and wrench: 2.450"-3.000" (62,2-76,2 mm)
	PLB-351	3.000"-3.650" (76,2-92,7 mm)
	PLB-352	3.650"-4.300" (92,7-109,2 mm)
	PLB-353	4.300"-4.950" (109,2-125,7 mm)
	PLB-354*	Universal Cutter, 3.000" (76,2 mm) long for chamfering
	PLB-355*	Chevrolet Thrust Face Cutter, brazed carbide tip
	PLB-356	.375" (9,5 mm) Wide Thrust Face Cutter with brazed carbide tip for all thrust faces except Chevrolet
	GAS1K-1	Kit contains five carbide indexable inserts, screws and one wrench
	TB907A	Package of 1 carbide indexable insert
	LN-570A*	Concentric Sleeve. Adapts boring bar to CH-75A Hone Driver.
	PM-1500A	Micrometer Setting Gage. Range: 1.500"-4.125" (38,1-104,8 mm)
	PWMM-3A*	Hex T Wrenches .118" (3 mm) for setting tool bits
	PWMM-5A*	.197" (5 mm) for feed collar bind bolt
See optional centering rings on this page	PLB-235*	Centering Rings for small block and big block Chevrolet
Not pictured	PLB-600A	Thrust Cutter Attachment

\*Standard equipment with PLB-100. Shipped in 2 pieces. Bar: 33 lbs. (73 kg). Housing: 37 lbs. (81,4 kg).

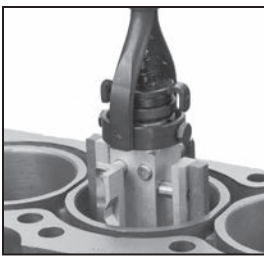

# Portable Hones & Accessories

## Sunnen Portable Cylinder Hones

Select stone sets desired on next page.

- The fastest and most accurate (to one-half thousandth) portable hone for cylinder reconditioning in cars, trucks, tractors, stationary engines.
- The only method that maintains alignment of the original bore.
- Reconditions cylinder bore with less stock removal than other methods-assures longer block life.
- Produces any finish specified by engine and ring manufacturers.
- Recommended for fast seating of chrome or moly rings.
- Correct stone length.
- Fast stock removal-up to five thousandths (0,13 mm) per minute.
- Can be set up in a few minutes-no studs to remove.
- All cylinder hones include AN-1105A molded storage box.

### SNJ-10 Portable Hone

Range: 1.250"-1.770" (31,5 mm-45,0 mm)

The SNJ-10 Portable Hone is recommended for sizing and finishing small holes in parts too heavy or awkward to stroke on a honing machine.

Includes a 2" (50,88 mm) drive shank and 12" (304,8 mm) extension.

Shipping Weight: Approx. 5 lbs. (2,3 kg)



### Recommended Stone Sets for Sunnen SNJ-10 Portable Hone

Diameter Range	Stone Sets		
	SNJ1-	SNJ2-	SNJ3-
1.250"-1.437" 31,75-36,50 mm		1.418"-1.604" 36,02-40,74 mm	1.580"-1.770" 40,13-45,00 mm
Deburring in Rough Bores, All Materials	<b>SNJ1-A47</b>	<b>SNJ2-A47</b>	<b>SNJ3-A47</b>
Fast Stock Removal in Bored, Ground or Deburred Holes in the following materials:			
Aluminum or Bronze	<b>SNJ1-J45</b>	<b>SNJ2-J45</b>	<b>SNJ3-J45</b>
Soft Brass	<b>SNJ1-J63</b>	<b>SNJ2-J63</b>	<b>SNJ3-J63</b>
Cast Iron	<b>SNJ1-J45</b>	<b>SNJ2-J45</b>	<b>SNJ3-J45</b>
Soft Steel	<b>SNJ1-A45</b>	<b>SNJ2-A45</b>	<b>SNJ3-A45</b>
Hard Steel (First Choice)	<b>SNJ1-A45</b>	<b>SNJ2-A45</b>	<b>SNJ3-A45</b>
Hard Steel (If A45 does not cut)	<b>SNJ1-A43</b>	<b>SNJ2-A43</b>	<b>SNJ3-A43</b>
Very Hard Steel (If A43 does not cut)	<b>SNJ1-J63</b>	<b>SNJ2-J63</b>	<b>SNJ3-J63</b>
Fine Finishing in the following materials:			
Aluminum or Bronze	<b>SNJ1-J87</b>	<b>SNJ2-J87</b>	<b>SNJ3-J87</b>
Soft Brass	<b>SNJ1-J85</b>	<b>SNJ2-J85</b>	<b>SNJ3-J85</b>
Cast Iron	<b>SNJ1-J87</b>	<b>SNJ2-J87</b>	<b>SNJ3-J87</b>
Soft Steel	<b>SNJ1-J87</b>	<b>SNJ2-J87</b>	<b>SNJ3-J87</b>
Hard Steel	<b>SNJ1-J85</b>	<b>SNJ2-J85</b>	<b>SNJ3-J85</b>

Note: All stone sets must be ordered separately.  
See page 42 for Plateau Honing Tools.

# Portable Hones & Accessories

---

## SN-75 Midget Portable Cylinder Hone

Range: 1.75"-2" (44-51 mm)  
Recommended for small compressors, outboard motors and similar small bore engines.

Includes 2" (50,8 mm) drive shank and 12" (304,8 mm) extension.



*Note: All stone sets must be ordered separately.*

*Shipping Weight: Approx. 5 lbs. (2,3 kg)*

---

## JN-95 Junior Portable Cylinder Hone

Range: 2"-2.6" (50,8-66 mm)  
Ideal for outboard motors, motorcycle and similar small bore engines within its range. Includes 2" (50,8 mm) drive shank and 12" (304,8 mm) extension.



*Note: All stone sets must be ordered separately.*

Stone Set Range:  
2.0"-2.2" (50,8-55,9 mm)  
2.2"-2.4" (55,9-60,9 mm)  
2.4"-2.6" (60,9-66,0 mm)

*Shipping Weight: Approx. 5 lbs. (2,3 kg)*

---

## AN-111 Standard Portable Cylinder Hone

Range: 2.5"-7" (63 mm-178 mm)  
Shipped with roughing and medium finishing stone sets, (M27J17) for range 2.7"-4.1" (69-104 mm) (M27J55). Stone sets available for complete range 2.5"-7" (63-178 mm). Includes 12" (304,8 mm) drive shank.

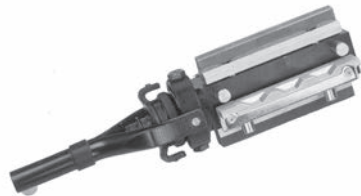

*Note: All stone sets must be ordered separately.*

*Shipping Weight: Approx. 9 lbs. (4,1 kg)*

---

## AN-112 Standard Portable Cylinder Hone

Same as AN-111 except does not include any stone sets. Includes 2" (50,8 mm) drive shank and 12" (304,8 mm) extension.



*Note: All stone sets must be ordered separately.*

*Shipping Weight: Approx. 7 lbs. (3,2 kg)*

---

## AN-815 Heavy-Duty Cylinder Hone

Range: 2.5"-15" (63-381 mm)  
Recommended for truck and stationary engines with cylinder bores 2.5"-15" (63-381 mm). Equipped with heavy-duty universal joint, 6" (152 mm) drive shank and 12" (304,8 mm) shank extension.



*Note: Order stone sets, master holder sets and stone supports separately.*

*Shipping Weight: Approx. 9 lbs. (4,1 kg)*

---

*Note: See chart at right for Stone Sets.*

# Portable Honers & Accessories

So that we may better serve all of our customers, Sunnen has consolidated our parts numbering system. This allows us to offer the highest quality tooling and abrasives at the lowest possible price. This catalog has both the "old" numbers and the new numbers, so that you can make the transition.

Please be assured, only the part number has changed. The part you order is the same quality Sunnen part that you have come to depend on for the industry standard engine building honing equipment.

## Stone Sets for Sunnen Portable Cylinder Honers



For Use in Cylinder Hone Models	Diameter Range		When Used In	Old	New	Old	New	Old	New	Old	New	Old	New	Extra Fine Finish Stone Set (400 Grit)	Polishing	Stone Length	
	inches	mm		Stone Set (70 Grit)	Stone Set (70 Grit)	Stone Set (150 Grit)	Stone Set (150 Grit)	Med. Finish Stone Set (220 Grit)	Med. Finish Stone Set (220 Grit)	Fine Finish Stone Set (280 Grit)	Fine Finish Stone Set (280 Grit)	Stone Set (600 Grit)	in		mm		
SN Midjet	1.75-2.0	44-51	Cast Iron	SN-100	<b>S18-J17</b>	SN-200	<b>S18-J45</b>	SN-300	<b>S18-J55</b>	SN-500	<b>S18-J65</b>	<b>S18-J87</b>	<b>S18-C05*</b>		4	102	
	2.0-2.2	51-56	Cast Iron Hardened Sleeves	JN-100 JN-130	<b>T20-J17</b> <b>T20-J11</b>	JN-200 JN-230	<b>S20-J45</b> <b>T20-J43</b>	JN-300	<b>T20-J55</b>	JN-500 JN-530	<b>T20-J65</b> <b>T20-J63</b>	<b>T20-J87</b> <b>T20-J85</b>	<b>T20-C05</b>		4	102	
JN Junior	2.2-2.4	56-61	Cast Iron Hardened Sleeves	JN-101 JN-131	<b>U22-J17</b> <b>U22-J11</b>	JN-201 JN-231	<b>U22-J45</b> <b>U22-J43</b>	JN-301	<b>U22-J55</b>	JN-501 JN-531	<b>U22-J65</b> <b>U22-J63</b>	<b>U22-J87</b> <b>U22-J85</b>	<b>U22-C05*</b>		4	102	
	2.4-2.6	61-66	Cast Iron Hardened Sleeves	JN-102 JN-132	<b>V24-J17</b> <b>V24-J11</b>	JN-202 JN-232	<b>V24-J45</b> <b>V24-J43</b>	JN-302	<b>V24-J55</b>	JN-502 JN-532	<b>V24-J65</b> <b>V24-J63</b>	<b>V24-J87</b> <b>V24-J85</b>	<b>V24-C05*</b>		4	102	
AN Standard and Heavy Duty	2.5-2.7	63-70	Cast Iron	AN-115	<b>G25-J17</b>	AN-215	<b>G25-J45</b>		<b>G25-J55</b>	AN-515	<b>G25-J65</b>	<b>G25-J87</b>	<b>G25-C05</b>		4	102	
	2.7-4.1	69-104	Cast Iron Short C. Iron Cyls. Deutsch Diesel Cyls. VW Air Cooled Cyls. Harley Davidson Chilled Iron Liners	AN-100 AN-100-71 AN-100-F	<b>M27-J17</b> <b>M27-J17-71</b>	AN-200 AN-200-71	<b>M27-J45</b> <b>M27-J45-71</b>	AN-300 AN-300-71	<b>M27-J55</b> <b>M27-J55-71</b>	AN-500 AN-500-71	<b>M27-J65</b> <b>M27-J65-71</b>	<b>M27-J87</b>	<b>MM33-C05†</b>		4	102	
AN Standard and Heavy Duty	3.5-5.5	89-139	Hardened Sleeves Steel	AN-130	<b>M27-J11</b>	AN-230 AN-200A	<b>M27-J43</b> <b>M27-A45</b>			AN-530 AN-500A	<b>M27-J63</b> <b>M27-A65</b>	<b>M27-J85</b> <b>M27-J87</b>	<b>MM33-C05†</b> <b>MM33-C05†</b>		4	102	
			Cast Iron Short C. Iron Cyls.	AN-101 AN-101-71	<b>N37-J17</b> <b>N37-J17-71</b>	AN-201 AN-201-71	<b>N37-J45</b> <b>N37-J45-71</b>	AN-301 AN-301-71	<b>N37-J55</b> <b>N37-J55-71</b>	AN-501 AN-501-71	<b>N37-J65</b> <b>N37-J65-71</b>	<b>N37-J87</b>	<b>NN40-C05†</b>		4	102	
AN Standard and Heavy Duty	4.7-15.0	119-381	Hardened Sleeves Steel	AN-131	<b>N37-J11</b>	AN-231 AN-201A	<b>N37-J43</b> <b>N37-A45</b>			AN-531 AN-501A	<b>N37-J63</b> <b>N37-A65</b>	<b>N37-J85</b> <b>N37-J87</b>	<b>NN40-C05†</b> <b>NN40-C05†</b>		4	102	
			Cast Iron Hardened Sleeves Steel	AN-106 AN-136	<b>W47-J17</b> <b>W47-J11</b>	AN-206 AN-236 AN-206A	<b>W47-J45</b> <b>W47-J43</b> <b>W47-A45</b>	AN-306	<b>W47-J55</b>	AN-506 AN-536 AN-506A	<b>W47-J65</b> <b>W47-J63</b> <b>W47-J65</b>	<b>W47-J87</b> <b>W47-J85</b>	<b>WW51-C05†</b> <b>WW51-C05†</b> <b>WW51-C05†</b>		4	102	
AN Keyway	2.5-3.3	64-84	Ported Cylinders		<b>GY25-J15*</b>		<b>GY25-J45</b>				<b>GY25-J65</b>	<b>GY25-J85</b>			4	102	
	3.3-4.2	84-107	Ported Cylinders		<b>MY33-J15*</b>		<b>MY33-J45</b>				<b>MY33-J65</b>	<b>MY33-J85</b>			4	102	
	4.0-5.6	102-142	Ported Cylinders		<b>NY40-J15*</b>		<b>NY40-J45</b>				<b>NY40-J65</b>	<b>NY40-J85</b>			4	102	
	4.5-6.0	114-152	Ported Cylinders		<b>WY51-J15</b>		<b>WY51-J45</b>				<b>WY51-J65</b>	<b>WY51-J85</b>			4	102	
Approximate Surface Finish in Microinches (Ra)			Cast Iron Hardened Sleeves Steel	120 55 -	- - -	45 30 32	- - -	32 20 20	32 20 20	20 12 15	- - -	8 5 7	3 2 3		-	-	

\*Special, two week after receipt of order.

†Range on these sets as follows: MM33-3.3"-4.2"(84-107 mm), NN40-4.0"-5.6"(102-142 mm), WW51-4.5"-9.2"(114-234 mm).

‡Use this series of Stone Sets with Master Holder Sets and Stone Support (order below). Shipping Weight of all Stone Sets approximately 1.25 lbs. (.5 kg) per set.

## Stone Supports and Master Holder Sets

For Use In All AN Model Cylinder Honers	Single Length Master Holder Sets			Stone Supports		Double Length Master Holder Sets		
	 <p>For range 4.7"-15.0" (119-381 mm). One required for each range shown. Order stone sets separately.</p>			 <p>To provide stability and prevent chatter, stone supports must be used in diameters above 6.0" (152 mm). For use with both single length and double length Master Holder Sets.</p>		 <p>For range 4.7"-15.0" (119-381 mm). Uses two sets of stones in line for 8.0" (203 mm) stone length. One required for each range shown. Order stone sets separately.</p>		
	Range		Part Number	Part Number		Range		Part Number
inches	mm	Ship Wt. 3 lbs (1,4 kg)	Ship Wt. 2.5 lbs. (1,1 kg)		inches	mm	Ship Wt. 5 lbs (2,3 kg)	
4.7-7.0	119-178	<b>AN-355</b>	<b>Not required</b>		4.7-7.0	119-178	<b>AN-855</b>	
6.0-9.0	152-229	<b>AN-365</b>	<b>AN-260</b>		6.0-9.0	152-229	<b>AN-865</b>	
8.0-12.0	203-305	<b>AN-375</b>	<b>AN-280</b>		8.0-12.0	203-305	<b>AN-875</b>	
11.0-15.0	279-381	<b>AN-385</b>	<b>AN-290</b>		11.0-15.0	279-381	<b>AN-885</b>	

## PHT Plateau Honing Tools

Hone Body	For Diameter Range		Abrasive Sets * (320 GRIT)	Hone Body	For Diameter Range		Abrasive Sets * (320 GRIT)
	inches	mm			inches	mm	
SNJ	1.50-1.69	38,1-42,9	<b>SNJ1-PHT-732</b>	JN	2.40-2.60	60,9- 66,0	<b>JN0-PHT-732</b>
	1.67-1.86	42,4-47,2	<b>SNJ2-PHT-732</b>		2.60-2.80	66,0-71,1	<b>JN1-PHT-731</b>
	1.75-1.94	44,4-49,3	<b>SNJ3-PHT-732</b>		2.80-3.00	71,1-76,2	<b>JN2-PHT-731</b>
	1.91-2.10	48,5-53,3	<b>SNJ4-PHT-732</b>	AN Standard and Heavy-Duty AN-60	2.98-3.78	75,7-96,0	<b>GG-PHT-732</b>
	2.08-2.27	52,8-57,6	<b>SNJ5-PHT-732</b>		3.78-4.68	96,0-118,9	<b>MM-PHT-731</b>
SN	2.15-2.40	54,6-60,9	<b>SN-PHT-732</b>	4.48-6.08	113,8-154,4	<b>NN-PHT-731</b>	
				4.98-9.68	126,5- 245,9	<b>WW-PHT-731</b>	

\* Special order 2 weeks after receipt of order

# Portable Hones & Accessories

## Honing Aluminum Alloys

### High-Silicon Aluminum Alloy

Such as Porsche, Mercedes, Honda and Vega.

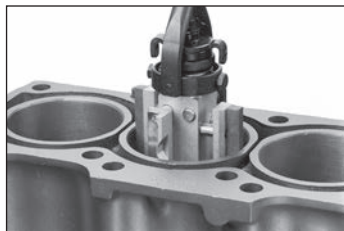

*Note: Sunnen MAN-845 or MB-30 is MANDATORY when honing ALL aluminum.*

### Tooling Required When Honing High Silicon Aluminum Blocks

- AN-111, AN-112 or AN-815 Cylinder Hone
- AN-80 Quick Coupler
- AN-1060 Heavy Duty Drill Motor
- MM33-J63 Roughing Stone Set
- MM33-J85 Finishing Stone Set
- MM33-C05 Polishing Stone Set
- MM33-F05 Felt Set
- AN-30 Sunnen Silicon Compound
- AN-35 Storage Box
- GA-2125 or GR-2125 Dial Bore Gage
- MAN-845 Honing Oil

### ANR-275 Remote Feed Heavy-Duty Cylinder Hone

Range: 2.5"-15" (63 mm-381 mm)



Must be used in a machine or honing rig. Illustration shows the ANR-275 Portable Hone assembled with Stone Support, Single Length Master Holder Set, Stone Set and 3" (76 mm) Drive Shank. 4" (104 mm) stone length or 8" (203 mm) stone length when two sets of stones are used with Double Length Master Holder Set.

*Shipping Weight: 13 lbs. (5,9 kg)*

*Order stone sets, master holder sets and stone supports separately.*

### AN-980 Chamfering Cone

Chamfers the sharp edges of cylinders for safe piston and ring installation. Handles all diameter cylinders or sleeves. Unit consists of tapered neoprene cone covered by long-lasting replaceable abrasive cone (plus a spare). Easy to use with .25" (6,3 mm) or larger drill.

*Shipping Weight: 1.5 lbs. (.68 kg)*

6 Replacement Cones in package:  
Order AN-994A

*Shipping Weight: 1 lb. (.45 kg)*

#### AN-980 Replacement Parts

Part No.	Description
AN-991A	Extension



### Superabrasive Stone Sets

#### Metal Bond Diamond and CBN Stone Sets

Available in G25, M27, N37, and W47 stone sizes. These stones can be used to increase stock removal rates or abrasive life when compared to A or J stones or Resin or Vitrified Diamond or CBN stones. First time users of metal bond superabrasive stone sets must order \_\_\_-KB5X (G25-KB5X) Master Holder Set. Replacement stones can be ordered without reordering KB5X Master Holders.

Master Holder Number	Stone Set Number	Diameter Range mm	Diameter Range in.	
			mm	in.
G25-KB5X	G25-___XG55	64-69	2.5 - 2.7	
M27-KB5X	M27-___XG55	69-104	2.7 - 4.1	
N37-KB5X	N37-___XG55	89-140	3.5 - 5.5	
W47-KB5X	W47-___XG55	104-533	4.1 - 21	

The \_\_\_ in the stone set number is for the metal bond abrasive code. This stone set consists of two L16 super-abrasive stones and (6) A43CFG (G25), AN43BFG (M27), AN62BFG (N37), or AN341AFG (W47) roughing guides.

#### Vitrified Bond Diamond and Resin CBN Sets

For honing carbide, ceramic, glass and hardened steel. Available in 3.25" (82,55 mm) or 4" (101,6 mm) stone length. For 3.5" (82,55 mm) length, add -85 to stone number.

Diamond Stone	CBN Stone
DV-47	NR53 Resin Bond
DV-57	NR83 Resin Bond
DV-87	—
DV-07	—

### Additional Portable Accessories

#### Teflon-Mounted Hone Holders for Portable Hones

Used to "finish" oil-free air compressor cylinder sleeves. Provides a "slippery" Teflon coating that is compatible with Teflon rider rings. Made from 15% glass filled Teflon and are used on Sunnen Model AN-112, AN-815, and ANR-275 Portable Hones. (Smaller sizes are available for JN/JNR, and SN/SNR Portable Hones on a special order basis. Call Sunnen Products, Customer Service Department for information.)

These Teflon Hones are used following a 400 grit finishing stone. The recommended procedure when using Teflon stones is to use them dry and with light pressure. Eight full passes up and down the cylinder wall is usually sufficient.

#### Teflon-Mounted Hone Holders Available

4 Strips	8 Strips	Diameter Range	
		mm	in.
GG25-XB25+	GY25-XB25+	64-84	2.5-3.3
MM33-XB25+	MY33-XB25+	84-107	3.3-4.2
NN40-XB25+	NY40-XB25+	102-142	4.0-5.6
W47-XB25+	WY51-XB25+	114-11524,0	4.5-60

+ Special Order - Contact Customer Service

#### PHT Plateau Honing Abrasive 320 Grit Sets

For AN, ANR, GNH and GNR Hones Sunnen's PHT tools are used as a final finishing step, after initial honing to provide a plateau surface on cylinder walls.

Gen'l. Purpose 4 Brushes	Production 8 Brushes	Diameter Range	
		mm	in.
GG-PHT-732	GY-PHT-732	75,7-96,0	2.98-3.78
MM-PHT-731	MY-PHT-731	96,0-118,9	3.78-4.68
NN-PHT-731	NY-PHT-731	113,8-154,4	4.68-6.08
WW-PHT-731	WY-PHT-731	126,5-1524,0	4.98-60.0

# Portable Hones & Accessories

## Drive Shanks and Shaft Extensions for ANR-275 Hone

Furnished with 3" (76 mm) Drive Shank. Other shanks or extensions may be selected from the table below to make up any practical length (either drive shank can be used with any combination of extensions).

Length		Replacement Drive Shanks	Shaft Extensions	Shipping Weight	
inches	mm			lbs.	kg
3	76	<b>AN-608A</b>	None	.33	.15
6	152	<b>AN-618A</b>	None	.66	.30
9.25	235	None	<b>ANR-741</b>	2	.91
19	483	None	<b>ANR-742</b>	4	1.2
42.75	1086	None	<b>ANR-744</b>	8	3.6
72.25	1835	None	<b>ANR-746</b>	13	5.9

## GGN-150 Portable Mandrel Driver



For portable honing applications such as spindle bushings mounted on axles, and other jobs that cannot be taken to honing machine. Recommended for use with Lifetime Honing Units. For holes .75" (19,1 mm) I.D. and larger, where length is at least 4 times the diameter. Graduated adjustment knob advances and retracts honing stones. Use with any half-inch drill (12,7 mm) or larger, 450 rpm or less.

*Shipping Weight: 3 lbs. (1,36 kg)*

## AN-1075 Speed Control Unit



Furnished with on/off switch, fuse, AC cord and grounded AC outlet plug. Reduces rpm when used with AC/DC drill motors and motors (brush-type only) where ampere rating is 15 amps or less.

*Shipping Weight: 3 lbs. (1,4 kg)*

## AN-1060 Drill Motor Kit (115V, 60Hz)

*For Sunnen Portable Equipment and Cylinder Hones*

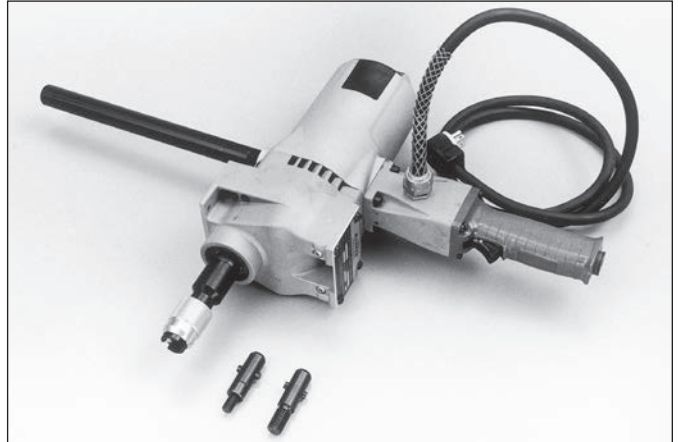

The AN-1060 Drill Motor has a speed torque relationship that is not found in ordinary electric drills. The power unit operates at 115V, has a no-load speed of 250 rpm and a full-load speed of 165 rpm. Has a full-load amp draw of 11 amps. Supplied with quick coupler, CH-179 adapter, and AN-97 and AN-87 yoke adapters. Optional CH-85 quick coupler.

*Shipping Weight: 23 lbs. (10,4 kg)*

## AN-1055 Drill Motor Kit (220V, 50Hz)

*(Does not come equipped with electrical plug)*

### "Quick-Coupler"

*Includes Yoke Adapter*

*Shipping Weight: 1 lb. (.45 kg)*



Two models fit all Sunnen Cylinder Hones-make cylinder honing an easier, faster operation.

Permits drill (electric or air) to be quickly coupled or uncoupled from cylinder hone. Allows operator to have both hands free for removing hone from cylinder or for stone changing operations.

AN-80 Quick-Coupler. Used with all SN, JN and standard AN model Cylinder Hones.

AN-85 Quick-Coupler. For use with AN-815 Heavy-Duty Cylinder Hones.

Extra Yoke Adapters

AN-87 For use with AN-80 Quick-Coupler.

AN-97 For use with AN-85 Quick-Coupler.

*Shipping Weight: .5 lb. (.23 kg)*

# Stone Sets for AN, ANR, GNH & GNR Honing Units

## AVAILABLE STONES:

In some cases, stones other than those recommended may hone faster or last longer. For long or repetitive production runs, it may be economical to choose a stone slightly harder or softer, coarser or finer. If the stone wears out too fast, use a harder stone; if it does not cut, use a softer stone. Stones in parentheses ( ) available 2 weeks after receipt of order.

### For Holes Without Keyways

### For Holes With Keyways

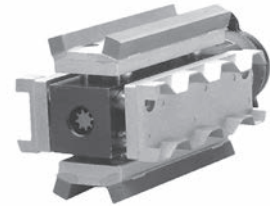
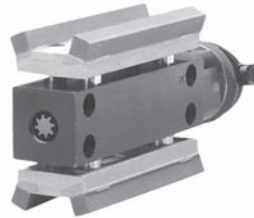
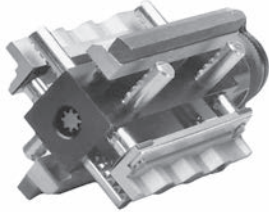

### General Purpose Stone Sets

### Guideless Stone Sets

### Keyway Stone Sets

### Maximum Keyway Width

Grit Size		General Purpose Stone Sets				Guideless Stone Sets				Keyway Stone Sets				
		2.5"-2.7" (64-69 mm)	2.7"-4.1" (69-104 mm)	3.5"-5.5" (89-140 mm)	4.1"-60"† (104-152 mm)	2.5"-3.3" (64-84 mm)	3.3"-4.2" (84-107 mm)	4.0"-5.6" (102-142 mm)	4.5"-60"† (114-152 mm)	.8" (20,3 mm)	.9" (22,8 mm)	1.2" (30,4 mm)	1.4" (35,5 mm)	
Aluminum Oxide	36	H/S												
	80 (2)	Soft	G25-A23	M27-A23	N37-A23	W47-A23	GG25-XM51	MM33-XM51	NN40-XM51	WW51-XM51	GY25-XM51	MY33-XM51	NY40-XM51	WY51-XM51
		Hard	G25-A25	M27-A25	N37-A25	W47-A25	GG25-A25	MM33-A25	NN40-A25	WW51-A25	GY25-A25	MY33-A25	NY40-A25	WY51-A23
	150 (4)	Soft	G25-A27	M27-A27	N37-A27	W47-A27	GG25-A27	MM33-A27	NN40-A27	WW51-A27	GY25-A27	MY33-A27	NY40-A27	WY51-A25
		Hard	G25-A43	M27-A43	N37-A43	W47-A43	GG25-A43	MM33-A43	NN40-A43	WW51-A43	GY25-A43	MY33-A43	NY40-A43	WY51-A43
			G25-A45	M27-A45	N37-A45	W47-A45	GG25-A45	MM33-A45	NN40-A45	WW51-A45	GY25-A45	MY33-A45	NY40-A45	WY51-A45
			G25-A45N	M27-A45N	N37-A45N	W47-A45N	GG25-A47	MM33-A47	NN40-A47	WW51-A47	GY25-A47	MY33-A47	NY40-A47	WY51-A47
	220 (5)	Soft	G25-A47	M27-A47	N37-A47	W47-A47								
		Hard	G25-A49	M27-A49	N37-A49	W47-A49								
	280 (6)	Soft		M27-A55	N37-A55	W47-A55								
		Hard				W47-A57								
			Soft	G25-A63	M27-A63	N37-A63	W47-A63							
Hard	G25-A65	M27-A65	N37-A65	W47-A65	GG25-A65	MM33-A65	NN40-A65	WW51-A65	GY25-A65	MY33-A65	NY40-A65	WY51-A65		
	G25-A67	M27-A67	N37-A67	W47-A67										

†These stones require Master Holder Sets.

# Stone Sets for AN, ANR, GNH & GNR Honing Units

**AVAILABLE STONES:**

In some cases, stones other than those recommended may hone faster or last longer. For long or repetitive production runs, it may be economical to choose a stone slightly harder or softer, coarser or finer. If the stone wears out too fast, use a harder stone; if it does not cut, use a softer stone. Stones in parentheses ( ) available 2 weeks after receipt of order.

For Holes Without Keyways

For Holes With Keyways

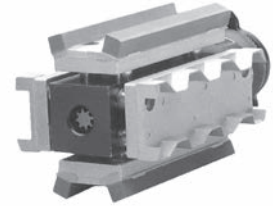
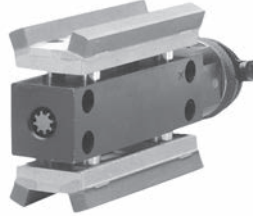
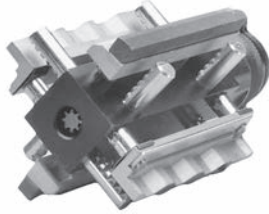

Keyway Stone Sets

Maximum Keyway Width

Grit Size		General Purpose Stone Sets				Guideless Stone Sets				Maximum Keyway Width				
		2.5"-2.7" (64-69 mm)	2.7"-4.1" (69-104 mm)	3.5"-5.5" (89-140 mm)	4.1"-60" <sup>†</sup> (104-152 mm)	2.5"-3.3" (64-84 mm)	3.3"-4.2" (84-107 mm)	4.0"-5.6" (102-142 mm)	4.5"-60" <sup>†</sup> (114-152 mm)	.8" (20,3 mm)	.9" (22,8 mm)	1.2" (30,4 mm)	1.4" (35,5 mm)	
Silicon Carbide	70 (1)	Soft	G25-J15 G25-J17	M27-J11 M27-J13 M27-J15 M27-J17	N37-J11 N37-J13 N37-J15 N37-J17	W47-J11 W47-J13 W47-J15 W47-J17 W47-J19	GG25-J15	MM33-J15	NN40-J15	WW51-J15	GY25-J15 GY25-J17	MY33-J15	NY40-J15	WY51-J15 WY51-J17
	150 (4)	Hard	G25-J45 G25-J47	M27-J43 M27-J45 M27-J47	N37-J43 N37-J45 N37-J47	W47-J43 W47-J45 W47-J47	GG25-J45	MM33-J45	NN40-J45	WW51-J45	GY25-J45 GY25-J47	MY33-J45 MY33-J47	NY40-J45	WY51-J43 WY51-J45 WY51-J47
		Soft	G25-J55	M27-J55	N37-J55	W47-J55								
	280 (6)	Hard	G25-J63 G25-J65 G25-J67	M27-J63 M27-J65 M27-J67	N37-J63 N37-J65 N37-J67	W47-J63 W47-J65 W47-J67	GG25-J65	MM33-J63 MM33-J65 MM33-J67	NN40-J65	WW51-J65	GY25-J65 GY25-J67	MY33-J65 MY33-J67	NY40-J65	WY51-J65 WY51-J67
		Soft	G25-J85 G25-J87	M27-J85 M27-J87	N37-J85 N37-J87	W47-J85 W47-J87	GG25-J85 GG25-J87	MM33-J85 MM33-J87	NN40-J85 NN40-J87	WW51-J85 WW51-J87	GY25-J85 GY25-J87	MY33-J85 MY33-J87	NY40-J85 NY40-J87	WY51-J85 WY51-J87
	500 (9)	Hard	G25-J95	M27-J95	N37-J95	W47-J95 W47-J97	GG25-J95	MM33-J95						
		Soft	G25-C05	M27-C05	N37-C05	W47-C05	GG25-C05	MM33-C05	NN40-C05	WW51-C05				
	600 (0)													

<sup>†</sup>These stones require Master Holder Sets.



# Portable Hones & Accessories

## SN-75 Hone

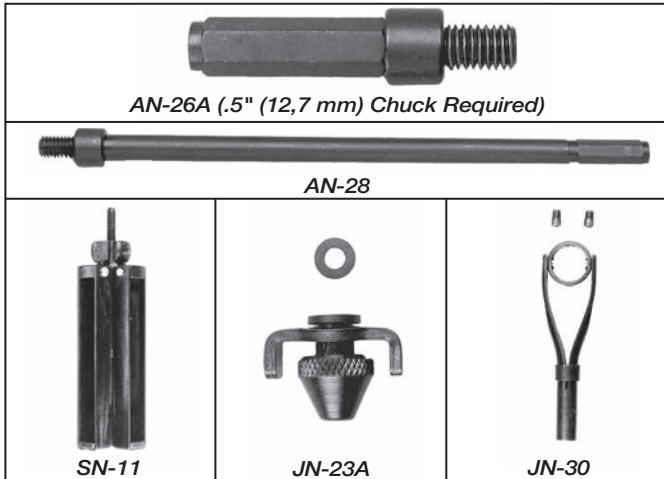

Part No.	Description
SN-11	Hone Body
JN-30	Universal Joint Complete
JN-23A	Adjusting Nut and Washer
AN-26A	3" (76,2 mm) Drive Shaft
AN-241	12" (304,8 mm) Extension Assembly

## JN-95 Hone

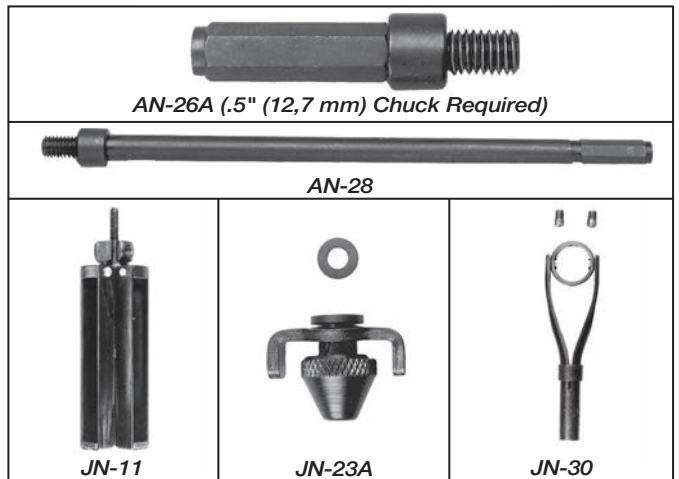

Part No.	Description
JN-11	Hone Body
JN-30	Universal Joint Complete
JN-23A	Adjusting Nut and Washer
AN-26A	3" (76,2 mm) Drive Shaft
AN-241	12" (304,8 mm) Extension Assembly

## AN-111 and AN-112 Hones

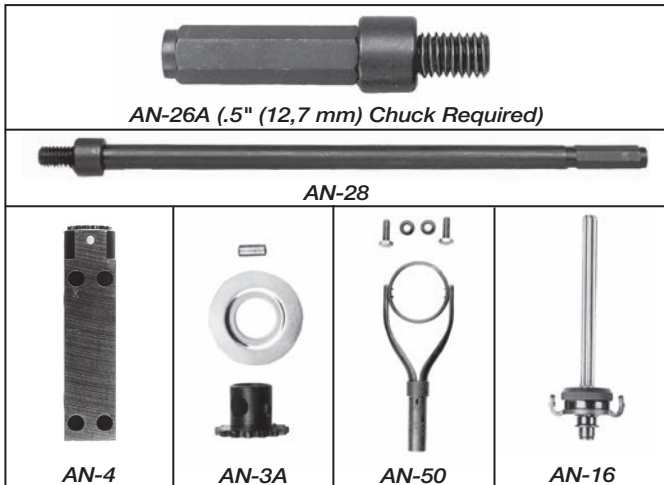

Part No.	Description
AN-4	Hone Body
AN-50	Universal Joint Complete
AN-16	Center Pinion Adjustment
AN-3A	Body Gear
AN-26A	3" (76,2 mm) Drive Shaft
AN-241	12" (304,8 mm) Extension Assembly

## AN-815 Hone



Part No.	Description
AN-650	Universal Joint
AN-604	Hone Body
AN-16	Center Pinion
AN-3A	Body Gear Set
AN-618A	6" (152,4 mm) Drive Shaft
AN-841	12" (304,8 mm) Extension Assembly

## AN-241 Drive Shaft



12" (304,8 mm), .4375-14 Thread  
 This is an economically priced replacement drive shaft for use with the SN-75, JN-95, AN-111, and AN-112 portable hones. Supplied as standard equipment with the AN-111. Requires .5" (12,7 mm) chuck  
 Shipping Weight: .75 lb. (.34 kg)

## AN Extension Couplers

Allows assembly of two or more AN-241 or AN-841 extensions for a longer reach with SN, JN and AN portable hones.



AN-630A .4375-14 Thd., for SN, JN, AN-111 and AN-112 portable hones.



AN-640A .625-11 Thd., for the AN-815.

Shipping Weight: .25 lb. (.11 kg)

# Portable Honers & Accessories

## Lifter Bore Honing in V-6 and V-8 Cylinder Blocks

Special mandrels are available for honing lifter bores in V-type engines. The mandrels are extended length keyway type. A keyway type mandrel is the best mandrel for this type of bore because it adds stability for this hand honing operation and also because of the typically large oil ports in the sides of the bore. The recommended power source is a .375" (10 mm) chuck capacity air drill with an approximate speed of 250 rpm. Honing oil is required.



## Tooling Required for Small Block Chevy

For Complete Honing Unit Order	
① ② ③ ④ ⑤ ⑥	
Part No.	Description
① AAY20-838BH-6LH Used with std. .843 dia. GM lifter	Extended Mandrel, 6" (15,2 cm) reach Diameter Range: .838"-.869" (21,29 - 22,07 mm)
① AAY20-869BH-6LH Used with .875 dia. Ford lifter	Extended Mandrel, 6" (15,2 cm) reach. Diameter Range: .869"-.900" (22,07-22,86 mm)
② Y20-W6LH	Extended Wedge
③ LN-3688A-6LH	Extended Retainer
④ P-180	Honall Head and Driver
⑤ PAK20-A	Adapter
⑥ Y20-J67	Recommended Stone

## Tooling Required for 231 Buick

For Complete Honing Unit Order	
① ② ③ ④ ⑤ ⑥	
Part No.	Description
① AAY20-869BH-675LH Used with .875 dia. Ford lifter	Extended Mandrel, 6.75" (17,1 cm) reach Diameter Range: .869"-.900" (22,07-22,86 mm)
① AAY20-838BH-675LH Used with .843 dia. GM lifter	Extended Mandrel, 6.75" (17,1 cm) reach Diameter Range: .838"-.869" (21,29-22,07 mm)
② Y20-W-675LH	Extended Wedge
③ LN-3688A-675LH	Extended Retainer
④ P-180	Honall Head and Driver
⑤ PAK20-A	Adapter
⑥ Y20-J67	Recommended Stone

Note: Could be used on the V-8's but is not as stable as the shorter 6" (15,2 cm) reach mandrel

## Tooling Required for Tall Deck Blocks

For Complete Honing Unit Order	
① ② ③ ④ ⑤ ⑥	
Part No.	Description
① AAY20-869BH-LK7X Used with .875 dia.	Extended Mandrel, 8.25" (20,9 cm) reach Diameter Range: .869"-.900" (22,07-22,86 mm)
① AAY20-838BH-LK7X Used with .843 dia.	Extended Mandrel, 8.25" (20,9 cm) reach Diameter Range: .838"-.869" (21,29-22,07 mm)
① AAY20-900BH-LK7X Used with .906 dia.	Extended Mandrel, 8.25" (20,9 cm) reach Diameter Range: .900"-.931" (22,86-23,65 mm)
① AAY20-931BH-LK7X Used with .937 dia.	Extended Mandrel, 8.25" (20,9 cm) reach Diameter Range: .931"-.962" (23,65-24,43 mm)
② Y20-W-LK7X	Extended Wedge
② Y32-1062PB-LP3X	For Nascar Blocks, 8" (20,3 cm) reach
③ LN-3688A-LK7X	Extended Retainer
④ P-180*	Honall Head and Driver
⑤ PAK20*-A	Adapter
⑥ Y20-J67*	Recommended Stone

For other applications, call Customer Service, Sunnen Products Co.

Shipment: Items marked with an asterisk (\*) are shipped from finished goods.

Items not marked with an asterisk (\*) are specials and are not shipped from stock. (If needed immediately call Customer Service, Sunnen Products Co. to check Special Products stock.)

# Piloted Portable Hones

Use to hone one bore in line with another bore on the same axis.  
Three models cover the diameter range of 44,5-533,4mm (1.75"-21").

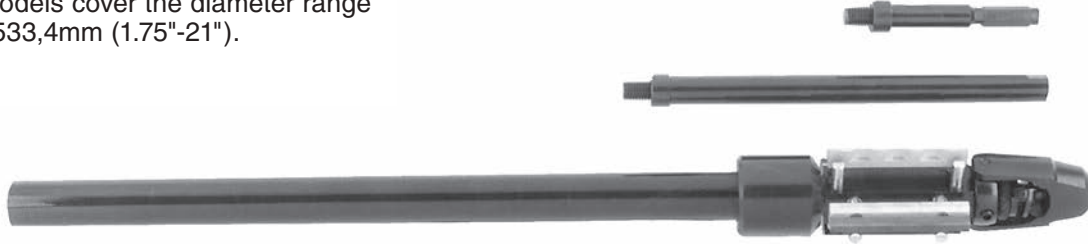

**AN-815-A40X Piloted Portable Hone**  
Diameter Range: 63.5mm-533.4mm (2.50"-21")

The SN-75-887X and JN-95-887X Piloted Portable Hones are furnished with a 25,4 mm (1") diameter pilot bar. The AN-815-A40X is furnished with a 38,1 mm (1-1/2") diameter pilot bar. The pilot bar must be long enough so that it will not stroke out of the pilot bushing during the honing operation. **BE SURE TO SPECIFY PILOT LENGTH BAR** on your order.

The pilot bushing is made by the user. It must be made to fit the bore before and after honing. The bushing O.D. should be tapered to fit the bore opposite the bore being honed. The bushing I.D. should be .025 mm (.001") larger than the diameter of the pilot on the hone.

The hone is used first in one bore with the pilot bushing positioned in the other bore. When this bore is finished, the pilot bushing is placed in the honed bore and the hone is entered from the other side to finish the second bore. Both outside ends of the tandem bores must be accessible.

SN-75-887X Piloted Portable Hone, 44,5 mm-50,8 mm (1.75"-2.00") diameter range, includes 76,0 mm (3") drive shaft, 304,8 mm (12") shaft extension, and 25,4 mm (1") diameter pilot bar up to 610 mm (24") long (does not include stone sets).

JN-95-887X Piloted Portable Hone, 50,8 mm-60,0 mm (2.00"-2.60") diameter range, includes 76,0 mm (3") drive shaft, 304,8 mm (12") shaft extension, and 25,4 mm (1") diameter pilot bar up to 610 mm (24") long (does not include stone sets).

Extra length 25,4 mm (1") diameter pilot bar for SN-75-887X or JN-95-887X hones will be supplied at an added price per foot or portion thereof, over the 610 mm (24") furnished with the hone.

AN-815-A40X Piloted Portable Hone, 63,5 mm-533,4 mm (2.50"-21.00") diameter range for light duty use in diameters larger than 381 mm (15"), includes 152,4 mm (6") drive shaft, 304,8 mm (12") shaft extension, and 38,1 mm (1.5") diameter pilot bar up to 610 mm (24") long (does not include stone sets, stone supports or master holder sets).

Extra length 38,1 mm (1.5") diameter pilot bar for AN-815-A40X hone will be supplied at an added price per foot or portion thereof, over the 610 mm (24") furnished with the hone.

The SN-75-887X Piloted Portable Hone uses the same S18 stone sets as the SN-75 Portable Hone. The JN-95-887X Piloted Portable Hone uses the same T20, U22 or V24 stone sets as the JN-95 Portable Hone. See page 42 for stone selection. Stone sets, stone supports and master holder sets used with the AN-815-A40X Piloted Portable Hone are found on page 42.

These hones may be driven by a heavy duty electric or air drill, or used in a drill press. To establish optimum rpm for your application, divide 1200 by the hole diameter in inches. Example:  $1200 \div 6" = 200$  (RPM). Or, divide 30000 by bore diameter in mm. Example:  $30000 \div 150 \text{ mm} = 200$  (RPM).

Hole Size		Recommended Drill Chuck Size	
in	mm	in	mm
1.75-5	44,45-127,0	5/8	15,8
5-15	127,0-381,0	3/4	19,0
15 and up	381,0 and up	1	25,4

A universal joint is built into each of these piloted portable hones. A second universal joint is required when the driving power is obtained from a drill press, or other rigid stroking device to provide the necessary full floating action at the honing head as shown below:

For Piloted Portable Hone	Order Additional Universal Joint
SN-75-887X	AN-70
JN-95-887X	AN-70
AN-815-A40X	AN-670 (Heavy-Duty)

## SNJ-8-749 Piloted Portable Hone



In-line honing for Harley Davidson® engine and transmission cases. Allows you to locate from tapered bearing side to ensure precise alignment on straight bearing side. Also eliminates the need of lapping bearing.

# Gages for Valve Guides and Seats

## P-310 Valve Guide Gage Set

The only way to be sure clearance is correct is to GAGE IT!

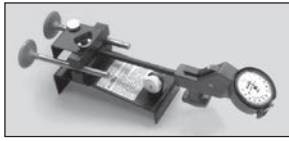

The Sunnen P-310 checks all types of guides for size and roundness. FAST! Set Includes:

Part No.	Description
P-300	Gage [Dial calibrated in .0002 in. (0,005 mm) increments]
P-312	Probe (.3125 in.)
P-344	Probe (.3437 in.)
P-350	Indicator only
P-360	Wrench
P-375	Probe (.375 in.)
P-610A	Setting Fixture
P-650A	Metal Storage Case (stores items listed plus 5 more probes)

For metric applications, order P-310M.

## Replacement and Additional Probes

Probe Part No.	Size Inches	Diameter Range	
		Inches	Millimeters
P-236	.2187	.224 to .264	5,69 to 6,70
P-250	.25	.238 to .278	6,05 to 7,06
P-281	.2812	.269 to .309	6,83 to 7,85
P-312*	.3125	.300 to .340	7,62 to 8,64
P-344*	.3437	.332 to .372	8,43 to 9,45
P-375*	.375	.363 to .403	9,22 to 10,24
P-406	.4062	.394 to .434	10,01 to 11,02
P-438	.4375	.426 to .466	10,82 to 11,84
P-469	.4687	.457 to .497	11,61 to 12,62
P-500	.5	.488 to .528	12,40 to 13,41

\*Included with P-310 Valve Guide Gage Set.

## Sunnen VRC-500 Precision Valve Checker



Provides a means of checking the runout of the engine valve face in relation to the valve stem.

### Features: Wide Range of Valve Sizes...

The VRC-500 can accommodate stem diameters from .25 to .75 in. (6-19 mm); head diameters from .625 to 4.5 in. (16-114 mm); and stem lengths up to 9.0 in. long (76 mm). The indicator reads in ten-thousandths (.0001 of an inch) increments.

### VRC-500M Metric Checker

Components of the VRC-500M are the same as VRC-500, except the indicator is replaced with a metric indicator calibrated in 0,005 mm increments. The diameter range is .25 to .75 in. (6-19 mm).

## Replacement Items for P300 Gage

Part No.	Description
P-350	Dial Indicator Assembly
G-5955A	Bezel and Crystal (round lens style)
G-59515A	Bezel and Crystal (flat lens style)

## VS-1005 Rapid Valve Seat Checker



Quickly and accurately checks out roundness and runout of the critical intersection between topping and seat angles. Thousandth reading indicator stays right side up for easy reading as gage checks full 360° of the seat. Works off valve pilot.

Set Includes:

VS-1010 Indicator Assembly with indicating wheel for Sunnen Pilots .389 in. (9,9 mm); plus these Indicator Wheel Assemblies:

VS-1625-44 VS-1875-44 VS-2125-44  
 VS-1750-44 VS-2000-44 VS-2250-44  
 VS-1020A Indicator Assembly only

## VS-1005 Rapid Valve Seat Checker

The VS-1005 Rapid Valve Seat Checker can be used on other manufacturers' pilots by ordering these indicating adapter wheels:

Part No.	Description
VS-1116A	.385 in. (9,8 mm) diameter Sioux Pilots
VS-1118A	.375 in. (9,5 mm) diameter K.O. Lee, Neway, Black and Decker Pilots

For metric applications, order VS-1015M.

## VSC-750 Rapid Valve Seat Checker



For use with the VSC-700 and SGM-700 Single-Blade, 3-Angle Seat Cutter Kit only. Compatible with the VS-875-44 and VS-1000-44 indicator wheels.

Indicator wheels ordered separately.

For metric applications, order VSC-750M.

# AG-Series Precision Gage



## For Pin Fitting and Rod Reconditioning

**AG-300 Range: .375"-3.375" (9,5-85,7 mm)**

**AG-400 Range: .720"-2.687" (18-68 mm)**

**Note: The AG-400 has fingers that are .600" longer than the AG-300  
(For use with larger diameter pistons with shorter wrist pins)**

### Sunnen AG-Series Precision Gage

Helps Sell Rod Reconditioning Service (Must be ordered separately-not included with honing machines.)

Dial reads directly in "tenths" (.0001").

- Checks rod journal bore for distortion.
- Assures correct size—within .0001"!
- Anyone can use it. No "feel" required!
- Measures size instantly!
- Wear-compensated gage points assure permanent accuracy!
- Assures exact fits required by today's high tech engines.

No rod should be reconditioned or pins fit without precise gaging. The only way to know the size is to measure the hole.

- Exact pin size is transferred to the AG-300 Gage with a wear-compensated setting fixture.
- Rugged construction. All moving parts are enclosed in housing. Never affected by vibration or shock.
- As shipped-Range .720"-2.687" (18-68 mm). Includes setting fixture, calibrator rings, medium and large extension point sets, accessory case, mounting bracket and instructions.

**Shipping Weight: approximately 25 lbs. (11,4 kg)**

### Midget Point Set AG-140 and AG-140L

Range .375"-.750" (9,5-19 mm). For checking pin fits on small bore engines. Fits AG-300 Gage without alterations. (See chart below...be sure to check serial number of gage before ordering midget point sets.) Set includes all required parts and metal storage box.

*The only gage made for both clearance and press type pin fits AND THE JOURNAL END OF CON-RODS.*



### Extra Large Point Set AG-340

Range 2.625"-3.375" (67-86 mm). Ideal for checking bores in large truck and tractor rods. Fits all AG-300 Gages.

Gage Point Sets	Point Sets	Part No.	Fits Gages Serial Numbers	Range
Each Midget Point Set includes all required parts & metal storage box.	Midget Point Sets	<b>AG-140</b> <b>AG-140L</b>	Under 13,000 13,000 and UP	.375"-.750" (9,5-19 mm)
	Standard Set	<b>AG-210*</b>	ALL GAGES	.720"-1.530" (18-39 mm)
These sets consist of two Gage Points and a centralizer point. Order by part number listed at right.	Medium Extension Sets	<b>AG-620*</b>	ABOVE 4,000-Heavy-duty type with Carbide Gage Balls	1.500"-2.250" (38-57 mm)
	Large Extension Sets	<b>AG-630*</b>	ABOVE 4,000-Heavy-duty type with Carbide Gage Balls	1.932"-2.687" (49-68 mm)
	Extra Large Extension Sets	<b>AG-340</b>	ALL GAGES	2.625"-3.375" (67-86 mm)
This set includes the AG-620 and AG-630 Point Sets. It is complete with both small and large calibration rings, adjustment wrench. Includes metal storage box.	Accessory and Point Set Kit	<b>AG-475L*</b>	13,000 and UP	1.500"-2.687" (38-68 mm)

#### Replacement Parts For AG-300

Part No.	Description	Part No.	Description	
<b>AG-50A*</b>	Dial Indicator	<b>AG-438A*</b>	Replacement Gaging Balls (package of 10) for AG-210 Standard Point Set	
<b>AG-34*</b>	Crystal			
<b>AG-26A*</b>	Face Plate			
<b>AG-299A*</b>	Setting Fixture (with wear pads)	<b>AG-456A*</b>		Small Calibration Ring
<b>PG-7A*</b>	Plastic Cover	<b>AG-465A*</b>		Large Calibration Ring
		<b>AG-450A*</b>	Adjusting Wrench	

\*These parts included with AG-300.

#### Replacement Parts For AG-400

Part No.	Description	Part No.	Description	
<b>AG-50A*</b>	Dial Indicator	<b>AG-438A*</b>	Replacement Gaging Balls (package of 10) for AG-210 Standard Point Set	
<b>AG-34*</b>	Crystal			
<b>AG-26A*</b>	Face Plate			
<b>AG-410A*</b>	Setting Fixture (with wear pads)	<b>AG-404*</b>		Small Calibration Ring
<b>PG-7A*</b>	Plastic Cover	<b>AG-465A*</b>		Large Calibration Ring
		<b>AG-450A*</b>	Adjusting Wrench	

#### Calibrating Rings for Quickly Setting AG-300 Gage to Connecting Rod Size

Part No.	Size	Part No.	Size
<b>RG-2125</b>	2.125" (53,9 mm)	<b>RG-2325</b>	2.325" (59,0 mm)
<b>RG-2225</b>	2.225" (56,5 mm)	<b>RG-2374</b>	2.374" (60,3 mm)
<b>RG-2237</b>	2.237" (56,8 mm)	<b>RG-2436</b>	2.436" (61,9 mm)
<b>RG-2239</b>	2.239" (56,9 mm)	<b>RG-2500</b>	2.500" (63,5 mm)
<b>RG-2250</b>	2.250" (57,1 mm)	<b>RG-2591</b>	2.591" (65,8 mm)
<b>RG-2275</b>	2.275" (57,8 mm)		
<b>RG-2100</b>	Complete Set of 11 ring gages listed above		

\*These parts included with AG-400.



# Dial/Digital Bore Gages

## Gages and Accessories

### GRM/GR-3000 Dial Bore Gage

**Diameter Range: .054" – 12.0"**  
**1,37mm – 304,8 mm**

**GR-3000** assembly consists of a .00001" reading indicator, probe retractor and probe retainer bushing in a reinforced nylon insulating shroud. Order **GRM-3000** for .002 mm reading. Shipping Weight: 2 lbs. (1 kg)



Order 1-4 for each diameter.

- ① Gage GR/GRM-3000
- ② Probe
- ③ Transfer Pin
- ④ Probe Extension

① Gage	Diameter Range		② Probe No.	③ Transfer Pin No.	Max. Gaging Depth		Overall Length		④ Probe Ext.
	in	mm			in	mm	in	mm	
<b>GR/GRM-3000</b>	.054 - .061	1,37 - 1,55	<b>G-1055</b>	<b>G-2037</b>	.43	11	6.6	167	<b>KZ1X-3500</b>  <b>See Note</b>
	.059 - .075	1,50 - 1,90	<b>G-1070</b>	<b>G-2059</b>	.63	16	6.9	174	
	.071 - .087	1,80 - 2,20	<b>G-1080</b>		.63	16	6.9	174	
	.081 - .096	2,05 - 2,45	<b>G-1090</b>		.63	16	6.9	174	
	.089 - .108	2,25 - 2,75	<b>G-1100</b>		<b>G-2089</b>	.82	21	7.1	
	.098 - .118	2,50 - 3,00	<b>G-1110</b>	.82		21	7.1	179	
	.108 - .128	2,75 - 3,25	<b>G-1120</b>	.82		21	7.1	179	
	.118 - .138	3,00 - 3,50	<b>G-1130</b>	.82		21	7.1	179	
	.128 - .148	3,25 - 3,75	<b>G-1140</b>	.82		21	7.1	179	
	.138 - .157	3,50 - 4,00	<b>G-1150</b>	.82		21	7.1	179	
	.148 - .167	3,75 - 4,25	<b>G-1160</b>	.82		21	7.1	179	
	.165 - .189	4,20 - 4,80	<b>G-1180</b>	<b>G-2264</b>		1.53	39	7.7	
	.185 - .209	4,70 - 5,30	<b>G-1200</b>		1.53	39	7.7	195	
	.205 - .228	5,20 - 5,80	<b>G-1220</b>		1.53	39	7.7	195	
	.224 - .248	5,70 - 6,30	<b>G-1240</b>		1.53	39	7.7	195	
	.244 - .268	6,20 - 6,80	<b>G-1260</b>		1.53	39	7.7	195	
	.264 - .287	6,70 - 7,30	<b>G-1280</b>		1.53	39	7.7	195	
	.283 - .307	7,20 - 7,80	<b>G-1300</b>		1.53	39	7.7	195	
	.303 - .327	7,70 - 8,30	<b>G-1320</b>		1.53	39	7.7	195	
	.323 - .346	8,20 - 8,80	<b>G-1340</b>	<b>G-2370</b>	1.53	39	7.7	195	
.343 - .366	8,70 - 9,30	<b>G-1360</b>	1.53		39	7.7	195		
.362 - .386	9,20 - 9,80	<b>G-1380</b>	1.53		39	7.7	195		
.370 - .417	9,40 - 10,60	<b>G-1400</b>	1.81		46	7.7	195		
.409 - .457	10,40 - 11,60	<b>G-1440</b>	1.81		46	7.7	195		
.449 - .496	11,40 - 12,60	<b>G-1480</b>	1.81		46	7.7	195		
.488 - .535	12,40 - 13,60	<b>G-1520</b>	1.81		46	7.7	195		

### Probe Extension

Available for probes .323" (8,2 mm) or larger. Probe extensions are 2.5" (63,5 mm) long, and up to three can be assembled together. Part Number: **KZ1X-3500**.

Probe extension is not intended for use with the **CF-540** setting adapter.

NOTE: It may be necessary to order one or more **KZ1X-3500** Probe extensions to reach the valve guides. The probe extensions may be larger in diameter than the valve guide, but will not interfere with the gaging probe.

### Gage Probes and Transfer Pins

Probes and pins must be ordered separately. Diameter ranges, gaging depths and part numbers are listed in chart.

**G-3005A** Probe and Transfer Pin  
 Storage case



# Dial/Digital Bore Gages Setting Fixtures



## CF-540 Size Setting Adapter

Centers gage probes between parallel reference surfaces on **CF-502** Setting Fixture. Serves as an "extra pair of hands" to help in nulling the gage on both the horizontal and vertical axis. Assures fast, accurate setup of the gage.

Shipping Weight:  
2 lbs. (1 kg)



Shown with CF-502 Setting Fixture.

## Setting Fixtures CF-502M (metric) 1,37 mm-50,8 mm CF-502 (inch) .054"-2.00"

For use with 3000, 4000, 6000, and 9000 Series Dial Bore Gages.

CF-502M comes with 0-51 mm micrometer head marked in .002 mm increments with precision lapped carbide anvils. Includes a ring gage checking standard and three interchangeable nests. (Use of CF-502M/CF-502 with 3000 series gage requires the purchase of CF-540 Size Setting Adapter.) Setting Master has a rugged, stress-relieved cast-iron base and may be used without removing it from its protective case. CF-502 is equipped with a 0"-2" micrometer head marked in .0001" increments.

CF-502M/CF-502 Shipping Weight:  
10 lbs. (4,5 kg)

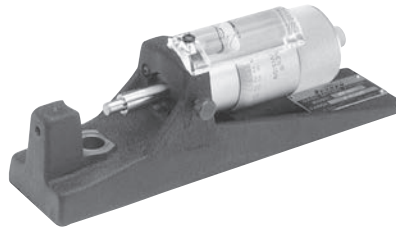

## Replacement Gage Nests For CF-502M Metric & CF502:

CF-502M	CF-550A	12,6 mm-19,1 mm
	CF-560A	18,8 mm-30,2 mm
	CF-570A	30,0 mm-50,0 mm

CF-502	CF-550A	.495"-.750"
	CF-560A	.740"-1.19"
	CF-570A	1.18"-2.00"

CF-137 Micrometer Adjusting Wrench

CF-138 Spindle Lock Knob

CF-544A Magnifier

CF-576A Calibration Ring

## Right Angle Attachment\*

Available for special conditions where it is difficult to read the gage or the total gage height causes a problem.  
Part Number: **KZ1X-90**.

\*Standard CF-502 Setting Fixture nest does not work with these accessories. Alternative methods of setting size must be used.

Available 4 weeks after receipt of order.



# Dial/Digital Bore Gages

## GA/GAM-4000 Series Gages

### Diameter Range:

**.495" – .750" (12,6 mm – 19,0 mm)**

Non-retractable gage with .0001" or (.002 mm metric) reading indicator. Capable of measuring to within .200" (5,0 mm) of the bottom of a blind hole. Indicators reading in .010 mm or .0005" are available on special order.



Part Number		Max. Gaging Depth		Overall Length		Shipping Weight	
Inches	Metric	in	mm	in	mm	lbs	kg
GA-4051	GAM-4051	2.5	62	7.3125	187	1.5	,7
GA-4101	GAM-4101	5	125	9.8125	251	1.5	,7
GA-4141	GAM-4141	7	175	11.8125	302	1.5	,7

### Replacement Parts For GA/GAM-4000 Series Gages:

G-275MA	Quick Setting Wrench (Metric reading)
G-275A	Quick Setting Wrench (Inch reading)
G-285A	Indicating Ball Removal Tool
G-289A	Indicating Finger Clamp
PBR-505A	Indicating Ball (.0625" Diameter Carbide)
G-222A	Centralizer Points (Package of 2)
G-261MA	#1 Point Assembly (metric) 12,6 mm-14,7 mm diameter
G-261A	#1 Point Assembly (inch) .495"-.580" diameter
G-262MA	#2 Point Assembly (metric) 14,7 mm-16,9 mm diameter
G-262A	#2 Point Assembly (inch) .580"-.665" diameter
G-263MA	#3 Point Assembly (metric) 16,9 mm-19,0 mm diameter
G-263A	#3 Point Assembly (inch) .665"-.750" diameter
G-249A	Nuts for Point Assembly (Package of 3)
G-249MA	Metric Nuts for Point Assembly (Package of 3)

Special Length Dial Bore Gages are available on a special order basis. GA/GAM-4000 Indicator cannot be peaked at lengths longer than 7" (175 mm) therefore gage accuracy is compromised.

To order special length dial bore gages, specify as follows: GA/GAM-4\_1X. The \_ is the desired gaging length multiplied by 2 (in inches). Available 4 weeks after receipt of order.

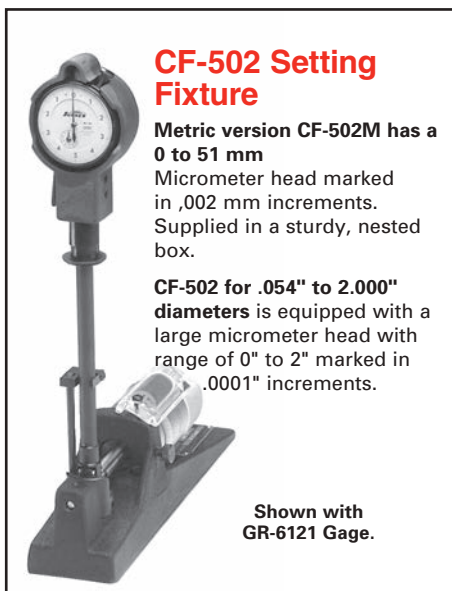

### CF-502 Setting Fixture

**Metric version CF-502M has a 0 to 51 mm** Micrometer head marked in .002 mm increments. Supplied in a sturdy, nested box.

**CF-502 for .054" to 2.000" diameters** is equipped with a large micrometer head with range of 0" to 2" marked in .0001" increments.

Shown with GR-6121 Gage.

## GR/GRM-6000 Series Gages for Lifters

### Diameter Range:

**.740" – 1.190" (18,8 mm – 30,2 mm)**

Retractable gage with .0001" or (.002 mm) metric reading indicator. Capable of measuring to within .270" (6,8 mm) of the bottom of a blind hole. Indicators reading in .0005" or (.010 mm) are available on special order.



Part Number		Max. Gaging Depth		Overall Length		Shipping Weight	
Inches	Metric	in	mm	in	mm	lbs	kg
GA-6051	GAM-6051	3.5	88	9.1875	235	2	1
GA-6121	GAM-6121	6	150	11.6875	298	2	1
GA-6241	GAM-6241	12	300	17.6875	451	2	1

### Replacement Parts For GR/GRM-6000 Series Gages

G-375MA	Quick Setting Wrench (Metric reading)
G-375A	Quick Setting Wrench (Inch reading)
G-385A	Indicating Ball Removal Tool
G-389A	Indicating Finger Clamp
PBR-506A	Indicating Ball (.0937" Diameter Carbide)
G-327A	Centralizer Points (Package of 2)
G-361MA	#1 Point Assembly (metric) 18,8 mm-22,6 mm diameter
G-361A	#1 Point Assembly (inch) .740"-.890" diameter
G-362MA	#2 Point Assembly (metric) 22,6 mm-26,4 mm diameter
G-362A	#2 Point Assembly (inch) .890"-1.04" diameter
G-363MA	#3 Point Assembly (metric) 26,4 mm-30,2 mm diameter
G-363A	#3 Point Assembly (inch) 1.04"-1.19" diameter
G-349A	Nuts for Point Assembly (Package of 3)
G-349MA	Metric Nuts for Point Assembly (Package of 3)

Special Length Dial Bore Gages are available on a special order basis. GR/GRM-6000 Indicator cannot be peaked at lengths longer than 12" (305 mm) therefore gage accuracy is compromised.

To order special length dial bore gages, specify as follows: GR/GRM-6\_1X. The \_ is the desired gaging length multiplied by 2 (in inches). Available 4 weeks after receipt of order.

Gage Point No.	Diameter Range	
	in	mm
1	2.000-2.375	50-60
2	2.375-2.750	60-70
3	2.750-3.125	70-79
4	3.125-3.500	79-89
5	3.500-3.875	89-98
6	3.875-4.250	98-108
7 + 2	4.250-4.625	108-117
7 + 3	4.625-5.000	117-127
7 + 4	5.000-5.375	127-137
7 + 5	5.375-5.750	137-146
7 + 6	5.750-6.000	146-150



# Dial/Digital Bore Gages

## GR/GRM-9000 Series Gages

**Diameter Range: 1.18" – 2.0" 30,0 mm – 50,8 mm**  
Retractable gage with .0001" or (.002 mm metric) reading indicator. Capable of measuring to within .335" (mm) of the bottom of a blind hole. Indicators reading in .0005", or 010 mm are available on special order.



Part Number		Max. Gaging Depth		Overall Length		Shipping Weight	
Inches	Metric	in	mm	in	mm	lbs	kg
GR-9071	GRM-9071	3.5	88	9.25	237	4	1,8
GR-9121	GRM-9121	6	150	11.75	300	4	1,8
GR-9241	GRM-9241	12	300	17.75	452	4	1,8

### Replacement Parts For GR/GRM-9000 Series Gages:

G-475MA	Quick Setting Wrench (Metric reading)
G-475A	Quick Setting Wrench (Inch reading)
G-485A	Indicating Ball Removal Tool
G-489A	Indicating Finger Clamp
PBR-503A	Indicating Ball (.125" Diameter Carbide)
G-427A	Centralizer Points (Package of 2)
G-461MA	#1 Point Assembly (metric) 30,0 mm-35,2 mm diameter
G-461A	#1 Point Assembly (inch) 1.18"-1.385" diameter
G-462MA	#2 Point Assembly (metric) 35,2 mm-40,4 mm diameter
G-462A	#2 Point Assembly (inch) 1.385" 1.59" diameter
G-463MA	#3 Point Assembly (metric) 40,4 mm-45,6 mm diameter
G-463A	#3 Point Assembly (inch) 1.59"-1.795" diameter
G-464MA	#4 Point Assembly (metric) 45,6 mm-50,8 mm diameter
G-464A	#4 Point Assembly (inch) 1.795"-2.0" diameter
G-449A	Nuts for Point Assembly (inch) (Package of 4)
G-449MA	Nuts for Point Assembly (metric) (Package of 4)

Special Length Dial Bore Gages are available on a special order basis. GR/GRM-9000 Indicator cannot be peaked at lengths longer than 25" (635 mm) therefore gage accuracy is compromised.

To order special length dial bore gages, specify as follows: GR/GRM-9\_1X. The \_ is the desired gaging length multiplied by 2 (in inches).

*Available 4 weeks after receipt of order.*

**Note:** Sunnen 2000 Series Dial Bore Gages can be extended to 12" 304,8 mm by adding oversize centralizer points and additional gage point extensions.

For gaging diameters in the range of 6"-12" (152,4-304,8 mm) order: **G-822A** Gage Extension Kit. Consists of: Two Oversize Centralizer Points, **G-632A** #7 Gage Point Extension, **G-634A** #8 Gage Point Extension.

2000 Series Gages assembled with **G-822A** Gage extension set cannot be used with **CF-1126** setting fixture when set for diameters above 8" (203,2 mm). Alternative methods of setting gage must be used.

**G-822C** Centralizer Point Only.

## GA/GAM-2000 Series Gages (Non-Retractable)

## GR/GRM-2000 Series Gages (Retractable)

**Diameter Range: 2.0" – 6.0" (50 mm – 150 mm)**

Non-retractable gage with .0001" or (.002 mm) metric reading indicator. Capable of measuring to within .500" (13 mm) of the bottom of a blind hole. Indicators reading in .0005" or (.010 mm) are available on special order.



Part Number		Max. Gaging Depth		Overall Length		Shipping Weight	
Inches	Metric	in	mm	in	mm	lbs	kg
GA-2031	GAM-2031	3	75	8	203	6	2,7
GA-2061	GAM-2061	6	150	11	280	6	2,7
GA-2121	GAM-2121	12	300	17	432	6	2,7
GA-2241*	GAM-2241*	24	600	29	737	6	2,7

\*Available 2 weeks after receipt of order.

Extension sleeves are available for converting GAM/GA-2000 Series Gages to different lengths. The following extension sleeves are available:

GA-203	Accessory Extension Sleeves 3" (75 mm)
GA-206	Accessory Extension Sleeves 6" (150 mm)
GA-212	Accessory Extension Sleeves 12" (300 mm)
GA-224	Accessory Extension Sleeves 24" (600 mm)

Retractable gage with .0001" or (.002 mm) metric reading indicator. Capable of measuring to within .500" (13 mm) of the bottom of a blind hole. Indicators reading in .0005" or (.010 mm) available on special order.

\*Furnished with metal case for accessories only.

Part Number		Max. Gaging Depth		Overall Length		Shipping Weight	
Inches	Metric	in	mm	in	mm	lbs	kg
GR-2061	GRM-2061	6	150	11	280	6	2,7
GR-2121	GRM-2121	12	300	17	432	6	2,7
GR-2241	GRM-2241	24	600	29	737	6	2,7

### Replacement Parts For 2000 Series Gages

PBR-503A	Indicating Ball (.125" Diameter Carbide)
G-522A	Centralizer Points (Package of 2)
G-532A	Nuts (Package of 6)
G-532MA	Nuts (metric) (Package of 6)
G-640A	Indicating Ball Removal Tool
G-610A	#1 Point Assembly 2.0"-2.375" (50,8 mm-60,3 mm)
G-611A	#2 Point Assembly 2.375"-2.750" (60,3 mm-69,8 mm)
G-612A	#3 Point Assembly 2.750"-3.125" (69,8 mm-79,4 mm)
G-613A	#4 Point Assembly 3.125"-3.500" (79,4 mm-88,9 mm)
G-614A	#5 Point Assembly 3.500"-3.750" (88,9 mm-98,4 mm)
G-615A	#6 Point Assembly 3.750"-4.250" (95,3 mm-107,9 mm)
G-632A	#7 Point Extension
G-634A	#8 Point Extension
G-645A	Gage Point Assembly Ball Removal Tool
G-638A	Gage Point Assembly Wrench

Special Length Dial Bore Gages are available on a special order basis. 2000 Series Indicators cannot be peaked at lengths longer than 65" (1650 mm) therefore gage accuracy is compromised. To order special length dial bore gages, specify as follows: G\_-2\_1X. The second \_ is the desired gaging length multiplied by 2 (in inches). *Available 4 weeks after receipt of order.*





# Dial/Digital Bore Gages

## Setting Fixtures CF-1126 (inch) CF-1126M (metric)



**Diameter Range: 2.0" – 8.0"**  
**(51 mm – 203 mm)**

For use with 2000 Series Dial Bore Gages. Makes gage setting fast and easy. Micrometer adjustment allows "dialing in" sizes. A precision tool, shipped with convenient storage case.

Shipping Weight: 9,5 kg  
(21 lbs.)

Eliminates micrometers and ring gages.  
Eliminates errors and

"feel" in setting gages. Sets 2000 Series gages in seconds.

Includes .0001" (.002 mm) micrometer head with precision lapped carbide anvils. Comes with a ring gage checking standard and precision setting standards in 1" (25,4 mm) increments. Setting Master has a rugged, stress-relieved, cast iron base. May be used without removing from its protective case.

Setting Fixtures are shipped complete with setting standards to cover 2"-6" (50 mm-152,4 mm) range. A setting standard is not required to measure in the 7"-8" (178 mm-203 mm) range. When measuring in the 6"-7" (152 mm-178 mm) range order:

**CF-260A** 6"-7" (inch)      **CF-360A** 152-178 mm (metric)

### CF-1126 Replacement Setting Standards:

<b>CF-220A*</b> 2"-3"	<b>CF-240A*</b> 4"-5"
<b>CF-230A*</b> 3"-4"	<b>CF-250A*</b> 5"-6"
	<b>CF-260A</b> 6"-7"

\*Included with CF-1126

### CF-1126M Replacement Setting Standards:

<b>CF-320A*</b> 50-75 mm	<b>CF-340A*</b> 100-125 mm
<b>CF-330A*</b> 75-100 mm	<b>CF-350A*</b> 125-150 mm
	<b>CF-360A</b> 152-178 mm

\*Included with CF-1126M

<b>CF-544A</b> Magnifier	<b>CF-215A</b> Calibrating Ring
<b>CF-137A</b> Spanner Wrench	<b>CF-215MA</b> Calibrating Ring (metric)

## Replacement Indicators for Sunnen Dial Bore Gages

Part No.	Qty.	Description
---	Ref.	<b>Dial Indicator Assembly includes</b>
<b>G595A</b>	1	Indicator (.0005 in. Reading)
<b>G595MA</b>	1	Indicator (0,01 mm Reading)
<b>G795A</b>	1	Indicator (.0001 in. Reading)
<b>G795MA</b>	1	Indicator (0,002 mm Reading)
<b>G596A</b>	1	Screw
<b>G597A</b>	1	Nut
<b>G59515A</b>	1	Bezel and Crystal Assembly - Flat Style Lens
<b>G59513A</b>	1	Bezel Clamp and Screw - Flat Style Lens
<b>G595-5A</b>	1	Bezel and Crystal Assembly - Round Style Lens
<b>G595-3A</b>	1	Bezel Clamp and Screw - Round Style Lens
<b>G795-1</b>	1	Bezel and Crystal Assembly - Flat Style Lens with Blue Bezel
<b>G795-2</b>	1	Bezel Clamp and Screw - Flat Style Lens with Blue Bezel

## E Series Electronic Dial Bore Gages Features

- 16 Models + Special Lengths. All 3000, 4000, 6000, 2000 Series Available - Add "E" Suffix on Part Number
- Metric/Inch Conversion .0001" or (.001 mm) Divisions
- Display Swivels 330° for any Gaging Position
- SPC Capability
- Preset, zero set, +/- direction and Go/No Go functions.
- Communicates with Computers.
- Large, easy-to-read LCD.
- GO/±NG judgment can be performed by setting upper and lower tolerance limits. The judgment result (GO/±NG) can be displayed in full-size characters.
- The positive/negative count resulting from the spindle's up/down movement can be toggled.
- Internal calculations using the simple formula of [F(x)=Ax] are available
- Employing the ABSOLUTE linear encoder, the ID-C always displays the spindle "Absolute Position" from the origin at power-on. Also unlimited response speed eliminates over-speed errors.
- The ID-C indicator face can be rotated 330° to an appropriate angle for easy reading.
- With SPC data output. Can be connected to a computer to input measurements directly into SPC software/spreadsheet
- Technical Data
  - Accuracy: 0.00012in
  - Resolution: 00005in 0.001mm (switchable)
  - Display: LCD
  - Length standard: ABSOLUTE electrostatic capacitance type linear encoder
  - Max. Response speed: Unlimited
  - Battery life: Approx. 5,000 hours under normal use
  - Dust/Water protection level: IP42 or IP53 (dust-proof type)
- Functions
  - Origin-set/Preset, Zeroset, GO/±NG judgment, Counting direction switching, Power ON/OFF,
  - Data output, inch/mm conversion
  - Alarm: Low voltage, Counting value composition error, Over-flow error, Tolerance limit setting error
  - Internal calculations using the simple formula of [F(x)=Ax] are available



## Accessories/Repair Parts for E Series

- LU2X1** Cable (2 Meter Length) Connect to USB Port
- G799A** Replacement Indicator and Bushing



# Dial/Digital Bore Gages

## GR-6241 and GR-9241 with Retractable Centralizers

For lifter bores, cam bearing bores, hydraulic valve bodies and cylinders.  
**Shipping Weight: 7 lbs. (3,2 kg)**

GR-6245 diameter range: .740" to 1.190" (18,8 mm to 30,2 mm)

GR-9245 diameter range: 1.180" to 2.0" (30,0 mm to 50,8 mm)

The GR-6245 and GR-9245 dial bore gages parallel the GR-2125 and GR-2245 in function. They are ideally suited for many small bore applications—fast, easy, accurate.

For metric applications, order:  
GRM-6245-range: 18,8 to 30,2 mm.  
GRM-9245-range: 30,0 to 50,8 mm.  
Dial is marked in .01 mm increments.



Indicators are available for gages.  
G795A .0001" (.003 mm)  
G595A .0005" (.0127 mm)

## GR-2245 Gage with Retractable Centralizers

For main bearing saddle bores and cam shaft bearing bores.

**Shipping Weight: 5 lbs. (2,3 kg)**

Diameter range: 2" to 6" (50 to 152 mm). Gages holes up to 24" (60,9 cm) long.

This gage incorporates identical features and benefits of the GR-2125 with the additional reach length of 24" (60,9 cm).

For metric applications, order GRM-2245.  
Diameter range: 50 to 150 mm.  
Dial is marked in .01 mm increments.

The GR-2245 is furnished with a storage case for accessories only.

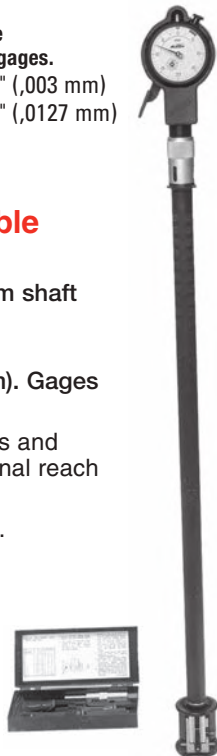

## GA-2125 and GR-2125

For cylinders, sleeves, large con rods... many other gaging jobs.

**Shipping Weight: 7 lbs. (3,2 kg)**

Diameter range: 2" to 6" (50,8 to 152,4 mm).

Gages holes up to 12" (304 mm) long.

The GA-2125 is self-aligning in the bore, requires no centering. Lets you explore the entire cylinder from top to bottom...in seconds.

The retractable self-centering mechanism in the gaging head of the GR-2125 makes it easy to gage interrupted bores typical of 2-cycle motor-cycle and marine engine applications without "hanging up". The retraction features allows precise exploration of a high performance cylinder without leaving telltale gaging marks.

- Gages are self-centering.
- Adjustable dial for easier reading.
- Dial is marked in .0005" increments.
- Carbide gaging points...for long life.
- Insulated grip eliminates "drift".
- Furnished in molded case with extension points and wrenches.

For metric models, order GAM-2125 or GRM-2125.

Range: 50 to 203 mm. Dial marked in .01 mm increments.

**NOTE: Special length gages are available on a special order basis. Write for product bulletin #P-4206 or call Customer Service, Sunnen Products Co. for information.**

*Note: Sunnen 2000 Series Dial Bore Gages can be extended to 12" (304,8 mm) by adding oversize centralizer points and additional gage point extensions.*

*For gaging diameters in the range of 6"-12" (152,4 mm-304,8 mm) order: G-822A Gage Extension Kit. Consists of: Two Oversize Centralizer Points, G-632A #7 Gage Point Extension, G-634A #8 Gage Point Extension.*

*2000 Series Gages assembled with G-822A Gage extension set cannot be used with CF-1126 Setting Fixture when set for diameters above 8" (203,2 mm). Alternative methods of setting gage must be used.*

Setting fixtures for Dial Bore Gages, see next page.



# Dial/Digital Bore Gage Setting Fixtures

Sunnen's unique setting fixtures allow fast, easy setting of Sunnen dial bore gages with no need for separate micrometers and ring gages. Sizes are simply "dialed in" with the micrometer adjustment, which eliminates errors due to "feel" in setting gages.

Two models combine to cover a continuous range of .054" to 8" in .0001" increments (1,37 mm to 203 mm in .002 mm increments). Both models feature a heavy stress-relieved cast iron base, lapped carbide micrometer anvils, and built-in magnifier for fast, accurate setup.

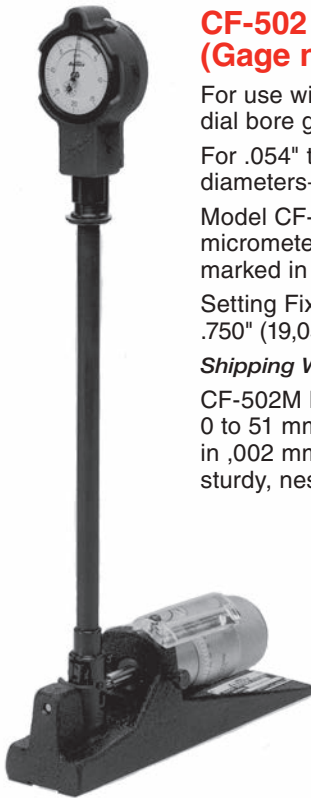

## CF-502 Setting Fixture (Gage not included)

For use with GR-6245 and GR-9245 dial bore gages.

For .054" to 2.000" (1,4 to 50,8 mm) diameters—

Model CF-502 is equipped with a large micrometer head with range of 0" to 2" marked in .0001" increments.

Setting Fixture comes with CF-576A .750" (19,05 mm) master calibrating ring.

**Shipping Weight: 13 lbs. (5,9 kg)**

CF-502M Metric Setting Fixture has a 0 to 51 mm micrometer head marked in .002 mm increments. Supplied in a sturdy, nested box.



## CF-125A (Not shown)

Nest for CF-1126

## CF-140 Adapter Kit (Not shown)

This adapter kit is required for the early model CF-1000 Setting Fixture so it can be used with the Sunnen CK-3280 as well as the current GA-2125 and GR-2245 Gages.

## CF-210A Setting Standard

Setting standard for CF-1000 setting fixture.

*Note: For electronic gages add "E" to the end of the part number.*



## CF-1126 Setting Fixture (Gage not included)

For use with GA-2125, GR-2125 and GR-2245 Dial Bore Gages. For 2" to 8" (51 to 203 mm) diameters.

The CF-1126 incorporates a tenth-reading micrometer head with precision carbide anvil. Accurate within .0001" (0,0025 mm). Ring gage checking standard included. Precision setting standards in 1" (25,4 mm) increments. Setting Master has rugged stress-relieved, cast iron base. May be used without removing from protective case.

**Shipping Weight: 21 lbs. (9,5 kg)**

The setting fixture itself covers the 7" to 8" (178 to 203 mm) range. In addition, the fixture is supplied with standards to cover the 2" to 6" (50 to 152,4 mm) range. Order additional setting standards to give complete 2" to 8" range as follows:

## CF-130A (Not shown)

Replacement Micrometer Anvil

## Gage Point Selection Table

Gage Point No.	Diameter Range	
	in	mm
1	2.000-2.375	50-60
2	2.375-2.750	60-70
3	2.750-3.125	70-79
4	3.125-3.500	79-89
5	3.500-3.875	89-98
6	3.875-4.250	98-108
7 + 2	4.250-4.625	108-117
7 + 3	4.625-5.000	117-127
7 + 4	5.000-5.375	127-137
7 + 5	5.375-5.750	137-146
7 + 6	5.750-6.000	146-150

# PG Bore Gaging System

## PG-700E Small Bore Precision Gage

**Diameter Range:** .090"-.379" (2,29 mm-9,63 mm)\*  
 Direct reading scale with .005" (.13 mm) range divided into increments of .00005" (.001 mm).  
 Order PG-700EM for metric applications.  
**Weight:** 20.5 lbs. (9,3 kg)  
**Dimensions**  
 (without fingers):  
 10.5" H x 7.75" W x 6.5" D (267 mm x 197 mm x 165mm)



PG-700

\*Covered with complete set of gaging fingers. Individual finger sets can be ordered for specific sizes. Order individual finger sets from the complete list at right.

## PG-2110 Snap in Plate

## PG-710E Small Bore Precision Gage

Identical to PG-700 except direct reading scale is .010" (.24 mm) wide and divided into increments of .0001" (.0025 mm). Order PG-710EM for metric applications.

## Gaging Fingers for PG-700 or PG-710 Precision Gage

To order individual finger pairs, consult the table below for size ranges and part numbers.



Each pair of gaging fingers is stamped with its size range and comes nested in an impact-resistant box. Available for sale only.

Individual Gaging Finger Shipping Weight: .5 lb. (.2 kg)

Diameter Range		Gaging Depth*		Accessory Fingers
inches	mm	inches	mm	
.090-.099	2,29-2,51	.281	7,14	PG-1090
.099-.109	2,51-2,77	.281	7,14	PG-1099
.109-.120	2,77-3,05	.281	7,14	PG-1109
.120-.132	3,05-3,35	.500	12,70	PG-1120
.132-.145	3,35-3,68	.500	12,70	PG-1132
.145-.159	3,68-4,04	.625	15,87	PG-1145
.159-.174	4,04-4,42	.625	15,87	PG-1159
.174-.190	4,42-4,83	.750	19,05	PG-1174
.190-.207	4,83-5,26	.750	19,05	PG-1190
.207-.225	5,26-5,72	.875	22,22	PG-1207
.225-.244	5,72-6,20	.875	22,22	PG-1225
.244-.264	6,20-6,71	1.000	25,40	PG-1244
.264-.285	6,71-7,24	1.000	25,40	PG-1264
.285-.307	7,24-7,80	1.250	31,75	PG-1285
.307-.330	7,80-8,38	1.250	31,75	PG-1307
.330-.354	8,38-9,00	1.500	38,10	PG-1330
.354-.379	9,00-9,63	1.500	38,10	PG-1354
Metal Storage Cabinet				PG-1418
COMPLETE SET of all Gaging Finger Pairs, including PG-1418 Metal Storage Cabinet.				PG-1401
Weight: 20 lbs. (9 kg)				

\* If bore can be measured from both ends, bore length can be double the gaging depth shown.

## Blind Hole Gaging Fingers for PG-700/PG-710 Gages

Special Blind Hole Gaging Fingers are available on special order basis. These fingers are non-adjustable and can only be used for a specific diameter size. These altered blind hole fingers can measure to within .040" (1,02 mm) of the bottom of the blind end of the bore. Recommend customer use a ring gage to set size on the gage.

How to order blind hole gaging fingers:

PG-\_\_\_\_ - \_\_\_\_ - HMOX The first \_\_\_\_ is the four-digit number of the standard gaging fingers for the diameter needed to be measured. The second \_\_\_\_ is the finished diameter of the bore to be measured, either in English or Metric units.

Examples: .2092" diameter. Order: PG-1202-2092-HMOX  
 2,89 mm diameter. Order: PG-1109-2,890-HMOX

Available 4 weeks after receipt of order.

## GAGE LEASING PROGRAM

Sunnen PG-700, PG-800 Series Gages, Setting Fixtures, and PG-250 Extension Fingers are also available on a unique lease plan. Leasing the Sunnen bore gaging system includes maintenance and updating by Sunnen. Contact KS & C Industries 1-800-247-7098 for complete leasing information.

Note: This program is not available outside of the United States.

# PG Bore Gaging System

## PG-800 Precision Gage

**Diameter Range:** .090"-4.310"  
(2,29 mm-109,47 mm)

The Sunnen "PG" Bore Gaging System is a unique mechanical gaging system that makes I.D. Gaging simple, reliable, and economical. Eliminates buying and maintaining costly master rings and air gage probes. Both gage and setting fixture are built for everyday use making them ideal for "in-process" inspection. Available in 00005" or .0001" (.001 mm or .0025 mm) reading scales.



PG-800

## PG-800E Precision Bore Gage

**Diameter Range:** .370" – 1.500" (9,4 mm – 38,1 mm)

Direct reading scale with .005" (.13 mm) range divided into increments of .00005" (.001 mm).

Overall size range is divided into two subranges .370"-.750" (9,4 mm-19,05 mm) and .750"-1.500" (19,05 mm-38,1 mm). Replaceable carbide gage points which can be rotated for long life. Size range can be increased to 2.9" (74,3 mm) by ordering PG-250 Extension Finger Set.

Order PG-800EM for metric applications. Dimensions: 10.5" H x 7.75" W x 8.375" D (267 x 197 x 213 mm) Gaging Depth: Small Side - .968" (24,6 mm) Large Side - 1.656" (42,06 mm) With PG-250 - 1.625" (41,27 mm) Weight: 20.25 lbs. (9,2 kg)



PG-800E

## PG-810-Z08X Precision Bore Gage

**Diameter Range:** 3.0" – 4.5" (76,2 mm – 114,3 mm)

Available for purchase only.

PG-810-Z08X is similar to the PG-810 Precision Bore Gage. Diameters 3.0"-3.750" (76,2 mm-95,25 mm) are measured on one side. Diameters 3.750"-4.5" (95,25 mm-114,3 mm) are measured on the opposite side. Dimensions: 10.5" H x 7.75" W x 8.75" D (267 x 197 x 222 mm)

Order PG-810M-Z08X for metric applications.

Weight: 21 lbs. (9,54 kg)

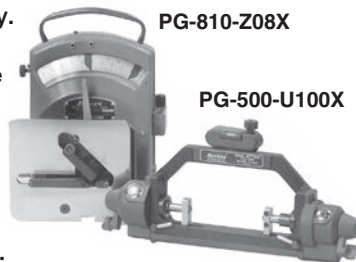

PG-810-Z08X

PG-500-U100X

## PG-810E Precision Bore Gage

Identical to PG-800 except direct reading scale is .010" (.24 mm) wide and divided into increments of .0001" (.0025 mm). Order PG-810EM for metric applications.

## PG-250E Extension Finger Set



Used with the PG-800 and PG-810 Precision Bore Gages. Extends the PG-800/PG-810 measuring range from 1.500" (38,1 mm) to over 2.900" (74,3 mm) diameter. Consists of two pairs of carbide extension points which mount onto the fingers of the PG-800/PG-810. Mounting screws are permanently

attached to extension points to avoid their loss. FOR SALE OR LEASE.

## PG-400E Setting Fixture

**Diameter Range:** .090" – 1.500" (2,29 mm – 38,3 mm)

This Setting Fixture is used to set the PGE-3000, PG-800, PG-810, PG-700 and PG-710 Precision Bore Gages.

Dimensional accuracy is guaranteed to be within  $\pm .000025"$  (.0006 mm) of nominal reading over the entire range of the instrument. Comes in a carrying case with a master calibrating ring traceable to the Bureau of Standards.

Order PG-400EM for metric applications.

Weight: 6.75 lbs. (3 kg) (with carrying case and accessories)



# PG Bore Gaging System

## PG-500-U100X Setting Fixture for PG-810-Z08X

(Similar to PG-500 Setting Gage.)  
Diameter Range: 2.890" – 4.310" (73,40 mm – 109,47 mm)  
Used to set 3.0"-4.310" (76,2 mm-109,47 mm) diameter range on PG-810-Z08X.

Also used with PG-800 Series Gage with PG-250 Extension Fingers and PG-2090-AM1X Auxiliary Face Plate to set diameters 2.890"-3.0" (73,4 mm-76,2 mm). Setting size on PG-810-Z08X from 4.310"-4.5" (109,47 mm-114,3 mm) must be done utilizing ring gages or gage blocks.

Order **PG-500M-U100X** for metric applications.  
Shipping Weight: 17 lb. (7,7 kg)

**PG-810-Z08X** and **PG-500-U100X** available from stock (limited quantity available). PG-2090-AM1X available three weeks after receipt of order.

## PG-2130 Flexible Hex Wrench

Use to dampen vibration when centralizing PG-400 on the PG-700/710 Precision Gage.

## PG-845 Tilting Gage Stand

A recommended accessory for the PG-810-Z08X Precision Gage. Lets the gage faceplate support the majority of the part weight. Used also with PGE-3000, PG-800/PG-810. Attaches to MB-2370 Gage Mounting Bracket.  
Weight: 4.5 lbs. (2,1 kg)



## PG-2110 Clip-On Auxiliary Faceplate

For PG-700/710 Precision Gage.



PG-4

Additional PG Gage Faceplates.

**PG-4 Auxiliary Faceplate for PG-700/PG-710.** A flat plate with ten holes designed to slip over the gaging fingers of a PG-700/PG-710. Reduces the opening size of the PG-2110 faceplate making it easier to measure thin walled parts. Hole sizes on PG-4 vary from .109"-.343" (2,77 mm-8,71 mm).



PG-5

**PG-10A Auxiliary Faceplate set for PG-800/PG-810 Precision Gage.** Consists of one PG-5 and PG-6 Faceplate similar to PG-4. PG-5 hole size .720" (18,3 mm), .820" (20,8 mm), and .920" (23,4 mm). PG-6 hole size .380" (9,7 mm), .430" (10,9 mm), .480" (12,2 mm), .530" (13,5 mm), .580" (14,7 mm), .630" (16,0 mm), and .680" (17,3 mm).



PG-6

# PG Bore Gaging System

## PG Bore Gaging Accessories

### Replacement Gage Points for PG-800 and PG-250

**PG-712A Point Set** Consists of Three Carbide Gaging and Three Mounting Screws for .740"-1.500" (18,8 mm-38,1 mm) diameter gaging fingers. Also used on non-centralizer gaging fingers on PG-250 Extension Finger Set.

**PG-714A Point Set** Consists of Three Carbide Gaging and Three Mounting Screws for .370"-.740" (9,4-mm-18,8 mm) diameter gaging fingers.

**PG-1007** Eccentric Centralizer with carbide ring used on both centralizer extension fingers of the PG-250 Extension Finger Set.

**PG-110A** Gage Point Removal and Installation Tool .370"-.740" (9,4 mm-18,8 mm).

**PG-90A** Gage Point Removal and Installation Tool .740"-1.500" (18,8 mm-38,1 mm).

**PG-120A** Tolerance Flag Adjusting Wrench.

### Blind Hole Gaging Points for PG-800 and PG-250

**PG-702A Blind Hole Point Set** Consists of Three Points and Screws .740"-1.500" (18,8 mm-38,1 mm). Also used on non-centralizer gaging fingers on PG-250 Extension Finger Set.

**PG-704A Blind Hole Point Set** Consists of Three Points and Screws 9,4 mm-.370"-.740" (18,8 mm) diameter gaging fingers.

**PG-LR6X Blind Hole Centralizer** For PG-250 Extension Finger Set  
1.5"-2.9" (38,1 mm-74,3 mm)

Note: Blind hole point sets measure to within .010" (0,25 mm) of the bottom of the blind hole.

PG-LR6X available four weeks after receipt of order.

## Gage Mounting Brackets

Recommended when any Sunnen Precision Bore Gage is used on a Sunnen Honing Machine. Mounting brackets reduce lost motion and fatigue and reduce runoff of honing oil.

Available for either right or left side mounting. All models adjustable for easiest access to gage.

To order, specify from chart.



Model No.	Description
MB-2370	For Left or Right Side of MBB-1650 or MBB-1660; Left Side of MBB-1670, MBB-1680, MBB-1690, MBB-1800, MBC-1800, MBC-1801, MBC-1802, MBC-1803, MBC-1804, MBC-1805. Weight: 12 lbs. (5,5 kg)
EC-7170	For Right Side of EC-3500.

## PG-25 Magnifying Glass



With spring clip. Made of 2.5x ground optical glass with a spring clip for mounting on PG-700 or PG-800 precision gage.







A LEGACY OF EXCELLENCE SINCE 1924.

## WORLDWIDE

Our global manufacturing, distribution, and sales and service network allows us to deliver quality Sunnen solutions worldwide.

And our state-of-the-art Technical Services Centers allow our technical experts to develop innovative solutions to customer application challenges. The Centers also provide answers for customer questions and training for Sunnen representatives around the world.

### **SUNNEN PRODUCTS COMPANY WORLD HEADQUARTERS**

**St. Louis, MO – USA**  
Phone 1.314.781.2100  
Fax 1.314.781.2268  
Toll Free 1.800.325.3670  
Email [sunnen@sunnen.com](mailto:sunnen@sunnen.com)  
[www.sunnen.com](http://www.sunnen.com)

### **SUNNEN AG ENNETAACH – SWITZERLAND**

Phone +41 71 649 33 33  
Fax +41 71 649 33 34  
Email [sales@sunnen.eu](mailto:sales@sunnen.eu)  
[www.sunnen.eu](http://www.sunnen.eu)

### **SUNNEN ITALIA S.R.L. ARESE – ITALY**

Phone +39 02 383 4171  
Fax +39 02 383 417 50  
Email [sunnen@sunnenitalia.com](mailto:sunnen@sunnenitalia.com)  
[www.sunnenitalia.com](http://www.sunnenitalia.com)

### **SUNNEN SAS SACLAY – FRANCE**

Phone +33 169 30 00 00  
Fax +33 169 30 11 11  
Email [info@sunnen.fr](mailto:info@sunnen.fr)  
[www.sunnen.fr](http://www.sunnen.fr)

### **SUNNEN BENELUX BVBA KONTICH – BELGIUM**

Phone +32 38 80 2800  
Fax +32 38 44 3901  
Email [info@sunnen.be](mailto:info@sunnen.be)  
[www.sunnen.be](http://www.sunnen.be)

### **SUNNEN PRODUCTS LTD. HEMPSTEAD HERTS – UNITED KINGDOM**

Phone +44 1442 39 39 39  
Fax +44 1442 39 12 12  
Email [hemel@sunnen.co.uk](mailto:hemel@sunnen.co.uk)  
[www.sunnen.co.uk](http://www.sunnen.co.uk)

### **SUNNEN DO BRASIL LTDA. SÃO PAULO – BRASIL**

Phone +55 11 4177-3824  
Fax +55 11 4362-3083  
Email [sunnen@sunnen.com.br](mailto:sunnen@sunnen.com.br)  
[www.sunnen.com.br](http://www.sunnen.com.br)

### **SUNNEN POLSKA Sp. z o.o. WARSZAWA – POLAND**

Phone +48 22 814 34 29  
Fax +48 22 814 34 28  
Email [sunnen@sunnen.pl](mailto:sunnen@sunnen.pl)  
[www.sunnen.pl](http://www.sunnen.pl)

### **SUNNEN RUS LLC MOSCOW – RUSSIA**

Phone +7 495 258 43 43  
Fax +7 495 258 91 75  
Email [sunnen@sunnen-russia.ru](mailto:sunnen@sunnen-russia.ru)  
[www.sunnen.ru](http://www.sunnen.ru)

### **SUNNEN S.R.O. STRAKONICE – CZECH REPUBLIC**

Phone +420 383 376 317  
Fax +420 383 376 316  
Email [sunnen@sunnen.cz](mailto:sunnen@sunnen.cz)  
[www.sunnen.cz](http://www.sunnen.cz)

### **SHANGHAI SUNNEN MECHANICAL Co. LTD.**

**SHANGHAI – CHINA**  
Phone +86 21 5813 3990  
Fax +86 21 5813 2299  
Email [shsunnen@sunnensh.com](mailto:shsunnen@sunnensh.com)  
[www.sunnensh.com](http://www.sunnensh.com)

Sunnen reserves the right to change or revise specifications and product design in connection with any feature of our products contained herein. Such changes do not entitle the buyer to corresponding changes, improvements, additions, or replacements for equipment, supplies or accessories previously sold. Information contained herein is considered to be accurate based on available information at the time of printing. Should any discrepancy of information arise, Sunnen recommends that user verify the discrepancy with Sunnen before proceeding.